

Report

ANIMO



Author(s):

- Sonia Gupta
- Krijn Blommestijn
- Kylian Dallongeville
- Michał Piotr Mamos
- Maximilian Frieder Paulsen

Acknowledgement

Glossary

Abbreviation	Description
CCTV	Closed-Circuit Television
DVR	Digital Video Recorder
EPS	European Project Semester
ESC	Electronic Speed Control
GPS	Global Positioning System

Abbreviation	Description
IP camera	Internet Protocol camera
ISEP	Instituto Superior de Engenharia do Porto
LCA	Life Cycle Analysis
NVR	Network Video Recorder
PCB	Printed Circuit Board
PEM Fuel	Proton exchange membrane (PEM) fuel
PESTEL	Political, Economic, Social, Technological, Environmental and Legal
PMBOK	Project Management Body of Knowledge
PTZ camera	Pan-Tilt-Zoom (PTZ) camera
S.D.	Standard Deviation
SWOT	Strength, Weaknesses, Opportunities and Threats
USB	Universal Serial Bus
WBS	Work Breakdown Structure
3D	3 Dimensions
4P	Product, Price, Place and Promotion

1. Introduction

The European Project Semester is an international program that provides engineering students with the opportunity to work on real-life projects in a multicultural environment. While the program is geared towards engineering students, students from other fields are also welcome to participate. EPS is offered by numerous universities throughout Europe and is designed to enhance students' communication skills, technical expertise, and real-world experience. The program typically lasts for a minimum of 15 weeks.

Each team consist of students of different academic background and nationalities, which creates a diverse and inclusive environment that promotes cross-cultural understanding and collaboration. The communication is done in English, which allows students from different language backgrounds to effectively communicate and work together, while also helping to develop their English language proficiency [[European Project Semester, 2023](#)].

During our EPS project, our team developed an innovative concept called ANIMO, which is designed to help farmers monitor their animals more effectively. We recognized that farmers with large cattle fields face significant challenges in maintaining and monitoring their farms efficiently, especially in remote areas where it is difficult to access the animals. To address this problem, we have developed a sustainable blimp that can be deployed over the farm to monitor the livestock without using thermal engine.

Our ANIMO blimp is equipped with high-resolution cameras and sensors that can capture detailed images and data about the animals, including their location and movement. Farmers can access this information through an app on their smartphones or tablets, allowing them to monitor their herds in real-time and identify any issues that require attention. For example, they can detect if an animal is injured or sick, if it is straying from the herd, or if it is behaving abnormally. Additionally, farmers can

move the blimps through the app, which provides an even more comprehensive view of their farms.

We have chosen Australia as our primary target market because it has a large number of farms with vast cattle fields, which are ideal for our ANIMO blimp. In fact, out of the top 10 farms in the world, eight are located in Australia. Our goal is to provide an affordable and reliable solution to help farmers in Australia and other similar regions improve their productivity and profitability while reducing their environmental impact.

1.1 Presentation

Our team, which goes by the name of Team 5, is made up of five motivated and energetic students from different academic backgrounds and nationalities. Our members include Sonia Gupta, Michał Piotr Mamos, Krijn Blommestijn, Kylian Dallongeville, and Maximilian Frieder Paulsen.

Table 1: Team

Name	Country	Field of Study
Sonia Gupta	Belgium	Electronics-ICT
Maximilian Frieder Paulsen	Germany	Mechanical Engineering
Michał Piotr Mamos	Poland	Biomedical Engineering and Technologies
Kylian Dallongeville	France	Energy and Thermal Engineering
Krijn Blommestijn	Netherlands	Industrial Product Design

As part of the European Project Semester at ISEP, we have a clear objective: to work on a project that is ethical and sustainable. With the invaluable guidance and support of our ISEP supervisors, we are determined to create a project that not only meets these criteria but also exceeds them.

We believe that our diverse backgrounds and skill sets will enable us to approach this project from a variety of perspectives and ultimately deliver a solution that is both innovative and impactful. We are excited to embark on this journey together and are eager to see where it takes us.

1.2 Motivation

1.2.1 EPS motivation

We were thrilled for a number of reasons to take part in the EPS at ISEP. First and foremost, the chance to visit the stunning city of Porto was certainly a motivating factor. But, the chance to collaborate with people from various backgrounds also piqued our interest. We were keen to learn how to collaborate with others who might approach problem-solving in a different way and to benefit from their distinct viewpoints and ideas.

Also, taking part in the EPS gave us the opportunity to challenge ourselves in a variety of ways. We were aware that strong English communication would be necessary for us to work in a group environment, therefore it was crucial to improve this skill. Also, we were excited to take on a project

outside of our regular areas of specialisation because we knew it would be a great chance to develop new abilities and broaden our knowledge. This experience offered a glimpse into the challenges and rewards of the real world.

1.2.2 Topic motivation

As a group, we looked over a number of project ideas and decided that the outdoor blimp was the most exciting one. It was a new idea that most of us had never really heard of before, while we were aware of large commercial or private zeppelins, we were unaware of any that could perform smaller duties. We were intrigued by the concept, and it inspired our creativity, which resulted in a wide range of potential uses. The options were limitless, ranging from use of transportation to directions in any city to even serving as props on film shoots. But we were all driven by a desire to build something that could actually improve people's lives.

During our brainstorming sessions, we focused on identifying global challenges that required resolution. As we conducted our study, we discovered a significant issue in Australia: the vast size of cattle farms and the difficulty in effectively monitoring livestock on such large scales. This discovery inspired us to think about potential fixes for the issue. We discovered that in these large farmed areas, standard monitoring equipment frequently failed to provide complete coverage and real-time data. This insight motivated us to look into new approaches, which is how we came up with the concept of using a blimp as a surveillance tool for Australian cattle farms.

The limits of traditional monitoring techniques are intended to be overcome by the deployment of a blimp equipped with cutting-edge sensors and technology. Through the introduction of a more effective and comprehensive method of monitoring the welfare and movement of cattle throughout Australia's vast farming landscapes, this technology has the potential to revolutionize livestock monitoring.

1.3 Problem

Monitoring farms can be a challenging and time-consuming task, especially for farmers who manage large fields or multiple properties. These challenges are amplified by the need to monitor crops and livestock regularly, which can be difficult and resource-intensive. Some of the most significant challenges include:

1. Time-consuming and resource-intensive: Monitoring farms requires a significant amount of time and resources, including manpower, equipment, and technology. This can result in increased costs and reduced efficiency, making it difficult for farmers to keep up with the demands of their business.
2. Limited coverage: Traditional monitoring methods, such as manual checks or stationary cameras, may not provide adequate coverage of the entire farm. This can result in blind spots or areas where monitoring is incomplete, potentially leading to undetected issues or problems.
3. Inefficient and ineffective: Traditional monitoring methods may not be effective in detecting certain issues, such as crop diseases or livestock health problems. This can lead to missed opportunities to address issues before they become more severe.
4. Environmental impact: The equipment used for monitoring can be carbon-intensive, contributing to greenhouse gas emissions and climate change but it can also have impacts on

biodiversity.

Outdoor blimps offer an innovative solution to these problems. They can be equipped with advanced monitoring technologies, such as cameras, sensors, and GPS, to provide farmers with a comprehensive view of their farms and livestock from a distance. This approach can significantly improve monitoring efficiency and reduce the need for manual checks, which can save time and resources.

Furthermore, outdoor blimps can be designed to be sustainable, using environmentally friendly materials like biodegradable plastics and reducing the carbon footprint associated with traditional monitoring methods. This makes them an excellent choice for farmers who want to adopt sustainable farming practices.

Overall, the use of outdoor blimps offers a viable solution to the challenges of monitoring farms, improving efficiency, reducing resource waste, and supporting sustainable farming practices.

1.3.1 Current scenario

Australia is home to several large animal farms, which are among the largest in the world. In fact, Australia is one of the world's largest agricultural producers, with a diverse range of farming operations across the country. One notable example is Anna Creek, which is one of the largest cattle stations in the world, spanning an area of 6,000,000 acres – a land mass that's bigger than Israel.

However, monitoring livestock on large farms can be a challenge. With so much land to cover, farmers face difficulties in tracking the health and welfare of their animals. While there are some advanced technologies available, such as remote sensing and environmental sensors, they can be expensive to implement and maintain, which may be a barrier for some farmers.

Another challenge is the lack of sustainable solutions available for managing large animal farms. With increasing concerns about environmental sustainability and animal welfare, farmers are under pressure to find new ways to manage their operations while reducing their impact on the environment. However, there are limited options available, and finding sustainable solutions that are both effective and economically viable can be a significant challenge.

Despite these challenges, the agriculture industry in Australia is continuously evolving and innovating, seeking new solutions to address the challenges of livestock monitoring and sustainability. Through collaboration and investment in technology and research, farmers are working to improve their operations and ensure the long-term viability of the industry.

1.4 Objectives

The objective of the ANIMO project is to create an innovative and sustainable solution for monitoring farms and improving the efficiency and sustainability of the agriculture industry. The project aims to provide farmers with a tool that can help them easily monitor their crops and livestock from a distance, thereby reducing the need for time-consuming and resource-intensive manual checks.

By creating an outdoor blimp that can be equipped with advanced monitoring technology, the project seeks to overcome the limitations of traditional monitoring methods and provide comprehensive

coverage of the entire farm. The blimp will be designed to be sustainable and environmentally friendly, minimizing the negative impact of monitoring on the environment.

Overall, the objective of the project is to support the growth and sustainability of the agriculture industry by providing farmers with an innovative and practical tool for monitoring their farms. By improving the efficiency of monitoring and reducing the impact on the environment, the project aims to help farmers improve their productivity, optimize resource usage, and manage their businesses more effectively.

1.5 Requirements

In order to achieve the intended outcome in a design project, requirements must be met. It serves as a guide and identifies the most significant requests of the client. All of these demands are listed in Table 2. The table of demands can be used to test the prototype after it has been constructed. Every requirement has a testing method.

1.5.1 Program of demands

Table 2: Program of demands table

Number	requirement	test method	date	points
1	The blimp can stay in the air for minimal one hour.	time for an hour	20-03-2023	
2	The blimp can operate with wind speed of max 2,5 m/s.	wind speed test	20-03-2023	
3	The weight of 1 kg of electrical components can be carried by the blimp.	test method	21-03-2023	
4	30 % of the used materials are recycled or can be recycled after the end of life.	test method	21-03-2023	
5	The blimp can stay in the same place while flying.	test method	21-03-2023	
6	The energy use is 60 % less than a comparable drone.	test method	21-03-2023	
7	The electronics are protected against moisture.	test method	21-03-2023	
8	Animals are not deterred by the product.	test method	21-03-2023	
9	The blimp does not crash when connection or power is lost.	test method	21-03-2023	
10	The control system is intuitive for the user.	test method	21-03-2023	

1.6 Functional Tests

A prototype of our blimp has been created to show and confirm how the engineered design performs. A prototype enables the concept to be validated, errors in the design can be more easily identified, and changes can still be made prior to major investments. The list below provides a brief overview of

the test; chapter 7 contains further information. Tests according to Table 2:

Table 3: caption

overview of tests	how will it be tested
The structure performance strength test. To see what forces the product can withstand.	With the use of a 3D program.
The reaction of the control system test.	test if the system works as been programmed
Acceleration of the blimp.	Are the motors giving the right power to control the blimp properly.
Landing and descending	The blimp must be able to land and descend by its own.
Timing to start up the system.	The user can get the system running within an hour.
Water resistance test.	The components in the gondola get a extreme weather test, with the help of an simulation.

1.7 Project Planning

The project planning for this project follows both PMBOK principles and SCRUM agile methodology figure 1. SCRUM is an agile project management approach that emphasises teamwork, communication, and iterative progress towards a goal. It is a framework that helps teams effectively collaborate on complex projects by breaking them down into smaller, manageable pieces. PMBOK is a guidebook that provides standard terminology, guidelines, and best practices for managing projects.

A scope is created to identify the tasks that must be completed for the entire project, which are listed in the backlog. The available period is divided into sprints of one week using a global sprint plan. The project is organised in equal periods throughout the whole project timeline, with certain tasks to be completed during each sprint. The team uses a comprehensive Gantt chart to keep track of task dependencies, start and end dates, and other important information. The first few prioritised items from the backlog are added to the current sprint at the start of it.

After each sprint, completed tasks are checked, and new ones are added to the new sprint plan. Further information about the sprints and tasks can be found in the team's wiki chapter 3. By employing the SCRUM approach and organising the project in sprints, the team can work collaboratively and effectively to achieve the best possible results.



Figure 1: Scrum methodology

1.8 Report Structure

You can access the report's structure here, which outlines the contents of each chapter and the information covered in detail. This structure will help you navigate the report effectively and find the specific information you need. It's important to review the structure first to ensure that you have a clear understanding of the topics covered and their sequence (see Table 4).

Table 4: Report structure

Task	Description
1 Introduction	The project will be introduced along with a summary of the problem and the approach taken to find a solution
2 State of Art	An analysis of the current state of our theme will be conducted, taking into account the latest research, trends, and data available
3 Project Management	Our approach to monitoring and managing the project's progress
4 Marketing Plan	To develop a successful marketing approach for our solution, we will perform market research and analysis, and then define a tailored marketing strategy
5 Eco-efficiency Measures for Sustainability	We will describe how our project promotes sustainability on social, economic, and environmental levels
6 Ethical and Deontological Concerns	Provide an explanation for the ethical basis or justification of the project
7 Project Development	The design and prototyping of the product followed by conducting final tests and documenting their results
8 Conclusions	Concluding summary of the report, along with future visions and recommendations
9 Bibliography	List of all sources referenced or consulted during the writing of this report

2. State of the Art

2.1 Introduction

History has seen the employment of blimps, also known as airships or dirigibles, for anything from transportation to military surveillance. Blimps have drawn interest recently because of their possible applications in agriculture, particularly for tracking animal movements. Compared to more conventional approaches that can be expensive and intrusive, including manual tracking or the use of GPS collars, this technology is considered as a possible replacement. Blimps offer a non-invasive approach to monitor animal movement and activity, allowing farmers and researchers to acquire vital insights into their animals' wellbeing and productivity.

We will examine the present status of research and development in the use of blimps for animal monitoring in agriculture in this state of the art. We will look at the benefits and drawbacks of this technology, including its potential to save labor costs and boost productivity as well as its restrictions due to weather and altitude. We'll also look into how blimps are now used in agriculture to monitor grazing patterns, spot problems with animal health, and determine how the environment affects animal behavior. The overall goal of this state-of-the-art is to offer a summary of the present trends and difficulties in the use of blimps for animal monitoring in agriculture, as well as a road map for further research and development in this area.

2.2 Indoor Blimps

Due to the steady flight behaviour and the decreasing weight of camera systems blimps are very suitable for indoor photography - especially for big events with a lot of people. Compared to drones there is little to none noise that would distract the guests of the event.

Similar to this application, the onboard camera system can also be used for long-term surveillance and monitoring purposes. The moveability and the flight time of the blimp has a lot of advantages when it comes to surveilling a large crowd in an arena. If needed the blimp can be manoeuvred to a critical spot in the crowd, without endangering the people within it or distracting them by noise. Because of the higher velocity and the more rapid movements of a The propellers of a quadcopter for example can be harmful if not navigated properly, because the quascopters movements are more rapid and, in most of the times, of a higher velocity.

Both previous applications can be combined with another - advertising and entertainment. The high ratio between the surface area of the envelope of a blimp to the mass of the blimp, makes it easy to have large surface areas that provide a great opportunity to display brand names.

The blimp can also be used for pedestrian navigation in large facilities [\[Yue Wang, Gang Zheng, Denis Efimov, Wilfrid Perruquetti, 2020\]](#) or for the navigation of people in large crowds. Visual and acoustic signals provide information about the shortest or safest route.

Another application is as an urban search and rescue blimp. This type of indoor blimp uses onboard technologies such as wireless cameras, sonar and infrared sensors to fulfil search and rescue tasks in an urban environment. The blimp can act autonomously or be teleoperated via joystick control. With the use of the mounted camera victims can be identified and marked for further help [\[Geoffrey](#)

Hollinger, Zachary Pezzementi, Alexander Flurie, Bruce Maxwell, 2005]. Figure 2 displays the configuration of this blimp.

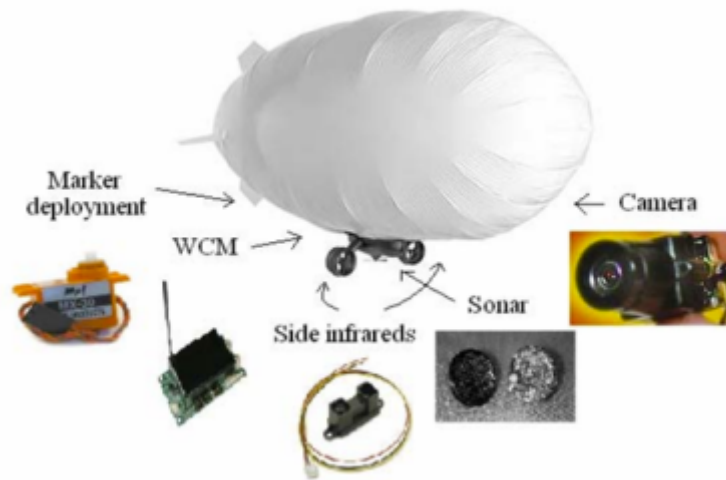

Figure 2: Urban search and rescue blimp [**Geoffrey Hollinger, Zachary Pezzementi, Alexander Flurie, Bruce Maxwell, 2005**]

2.3 Outdoor blimps

During review of the literature it can be provided that the blimps used in outdoor environment are commonly applied in entertainment industry figure 3. Nowadays most of them are inflatables with painted or printed advertisement. The inherent advantages of airships is their symbolic fuel consumption compared to airplanes. Many of them, like the previously mentioned inflatables, do not need fuel at all, they stay in the air because they are filled with a gas with a lower density than air, which makes them lighter and causes them to float. Another advantage of airships is the lack of a special place to fly, they can do it literally anywhere where nothing blocks access to the sky. Low energy demand compared to drones also means that the airship can stay in the air for a very long time, regardless of the distance it has travelled and the current weather conditions.



Figure 3: Inflatable [**Melissa Eddy, 2011**]

2.4 Floating of a blimp

A blimp or zeppelin is an aircraft inflated with a gas lighter than air which makes it float figure 4. The shape of the flying ship is maintained by the pressure of the gas within, there is no rigid internal structure so if the blimp deflates it loses its shape.

Blimps that are used today are mostly filled with helium gas. This is a non-flammable gas but also expansive. Previously these were filled with hydrogen, this gas is lighter than helium and provides more lift. Hydrogen is no longer allowed because it is a flammable gas. Instead of helium or other lifting gasses hot air can be used.

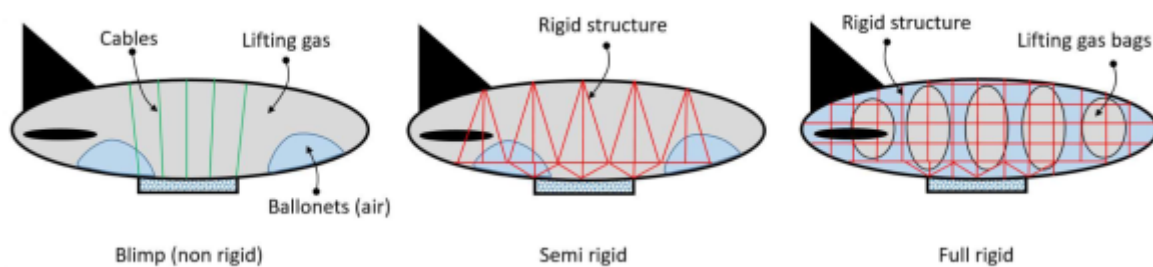

Figure 4: Blimp structure [Durga Vasudevan, Hariharan Mohan, Saarang Gagar, Ramesh Burela Gupta, 2019]

A blimp or airship controls its buoyancy in the air much like a submarine does in the water. The ballonets act like ballast tanks holding “heavy” air. When the blimp takes off, the pilot vents air from the ballonets through the air valves. The helium makes the blimp positively buoyant in the surrounding air, so the blimp rises. The pilot which could be auto pilot or controlled by a farmer throttles the engine and adjusts the elevators to angle the blimp into the wind. The cone shape of the blimp also helps to generate lift.

As the blimp rises, outside air pressure decreases and the helium in the envelope expands. The pilots then pump air into the ballonets to maintain pressure against the helium. Adding air makes the blimp heavier, so to maintain a steady cruising altitude, the pilots must balance the air-pressure with the helium-pressure to create neutral buoyancy.

To descend, the pilots fill the ballonets with air. This increases the density of the blimp, making it negatively buoyant so that it descends. Again, the elevators are adjusted to control the angle of descent.

2.5 Propulsion Technologies

Blimps use a variety of propulsion systems that allow them to manoeuvre or maintain a static floating posture. These devices either align a predetermined thrust vector or combine variously oriented propulsion vectors to produce thrust and control flight. There is no requirement to produce a lot of lift, in contrast to the use in aircraft.

2.5.1 Propeller

The most popular kind of propulsion used for blimps is the propeller – a device that combines at least 2 specially shaped blades, generates airflow and therefore thrust when rotated. Compared to the following technologies it is the oldest and is also utilized in airplanes. If applied in the propulsion system of a blimp, their primary task is manoeuvring in the horizontal plane, because the lift is generated by the gas stored in the envelope of the blimp. The use of one tiltable propeller unit on each side (left and right) allows for translational and rotational movement in every direction. This kind of configuration is shown in figure 5 [Aero Drum Ltd, 2018].



Figure 5: Adjustable Propellers mounted to the Envelope of a Blimp

2.5.2 Impeller

Another technology that can be used for propulsion is the impeller. It is used for spherical or ellipsoidal blimps and makes use of the Coanda effect – that describes the fact, that moving fluids always follow nearby surfaces, even if they are curved. If rotated the impeller sucks in air through its inlet and accelerates the air radially outwards, perpendicular to the inflowing air. The outflowing air sticks to the curved envelope, which is generating lift. Figure 6 displays the use of an impeller combined with this effect [Ying Hong Peh, Shane Kyi Hla Win, Shaohui Foong, 2022].

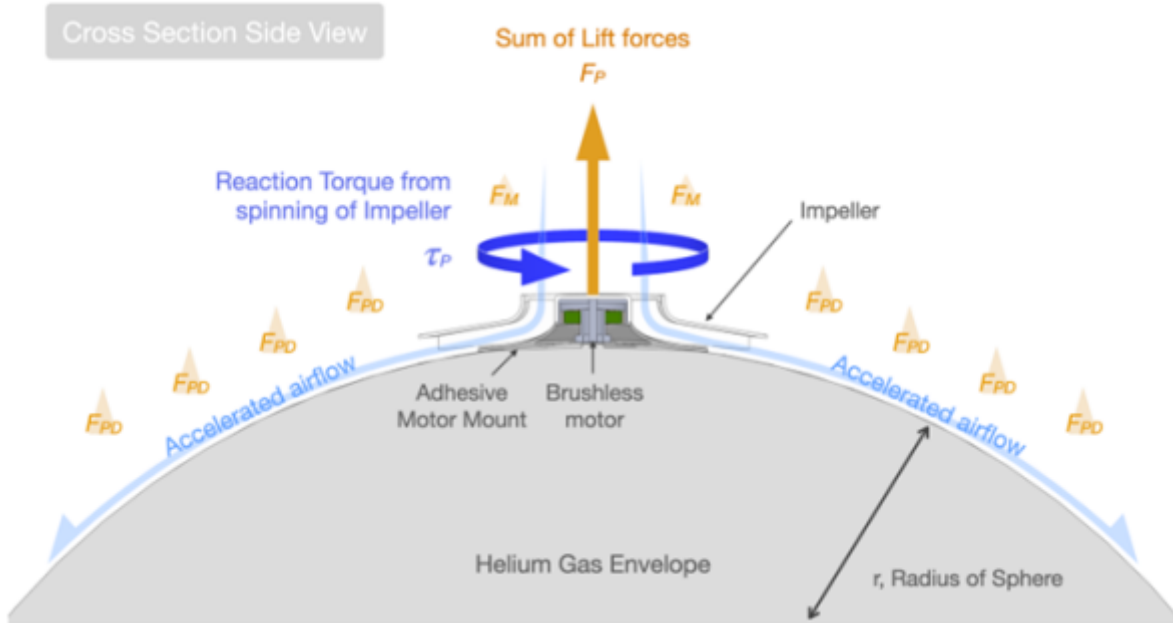

Figure 6: Working Principle of the Impeller if applied on a spherical blimp and combined with the use of the Coanda Effect

2.5.3 Ultrasonic Transducers

To solve the problem of the noise pollution a company named DOCOMO has developed a propulsion system of thrust-generating ultrasonic transducers shown in figure 7. The inaudible sound energy transmitted by these transducers creates an airflow, which is used for propulsion. The current system is capable of generating 180° steerable net force [Dave Rowntree, 2021]. Because of the detail scarcity in the reports of DOCOMO the underlying principle isn't accessible to the public yet.

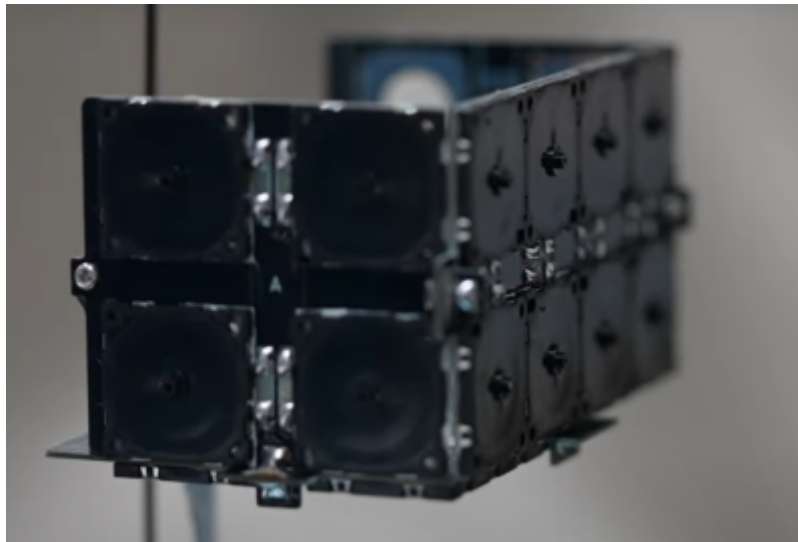

Figure 7: Ultrasonic Transducers by DOCOMO

2.5.4 Ionic Thrusters

Deriving from space technology this propulsion system is also suitable for application on blimps. This technology uses ionized atoms as a propellant. For the ionization the atoms are bombarded by high-energy electrons. Due to the collision the electrons rip out other electrons out of the initially neutral

atom, thus creating an ion. An electric field then accelerates these ions, which results in a thrust-generating beam [Dan Goebel, Richard Wirz, Israel Katz, 2007]. Figure 8 is used to convey this process.

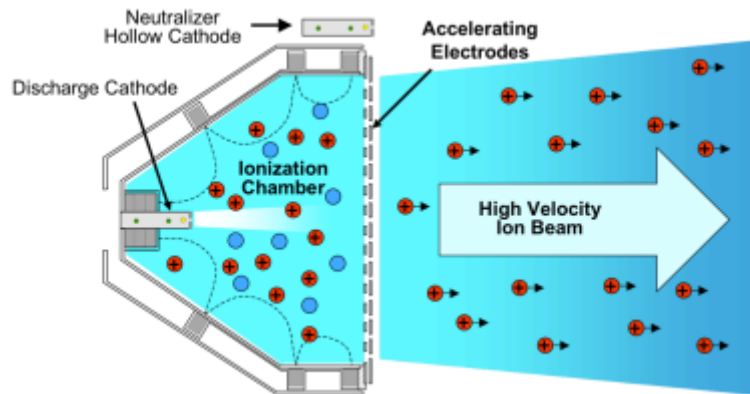

Figure 8: Illustration of an electron bombardment ion thruster

Because of the very low mass of the ions the net force is very small. An advantage is the lack of any noise. Opposite to that is the disturbance of nearby electrical devices and the potential harm of living organisms like humans or animals.

2.5.5 Biomimicry

A rather unknown and less traditional approach to blimp propulsion was made by Festo. The idea was to mimic the propulsion motion of flying or swimming animals and implement it in the design of the blimp [Karl Hastrich, 2011]. The assumption is that evolution derived motions for propulsion are the most efficient ones. Two examples are shown in the following figure 9 - a whale-like and a jellyfish-like blimp. Even though the energy consumption is very low, the complexity is very high and therefore an important disadvantage that has to be taken into consideration.





Figure 9: Different Types of Biomimicry

2.5.6 Piezoelectric Microblowers

Piezoelectricity is the conversion of vibration or stress into electricity and vice versa. In the case of the piezoelectric microblower the electrically generated vibration of a membrane is used to create an airflow and therefore thrust [Ltd. Murata Manufacturing Co., 2023]. So basically, it is a specialized air pump, which uses the Venturi effect among other things. The generated airflow is shown in figure 10.

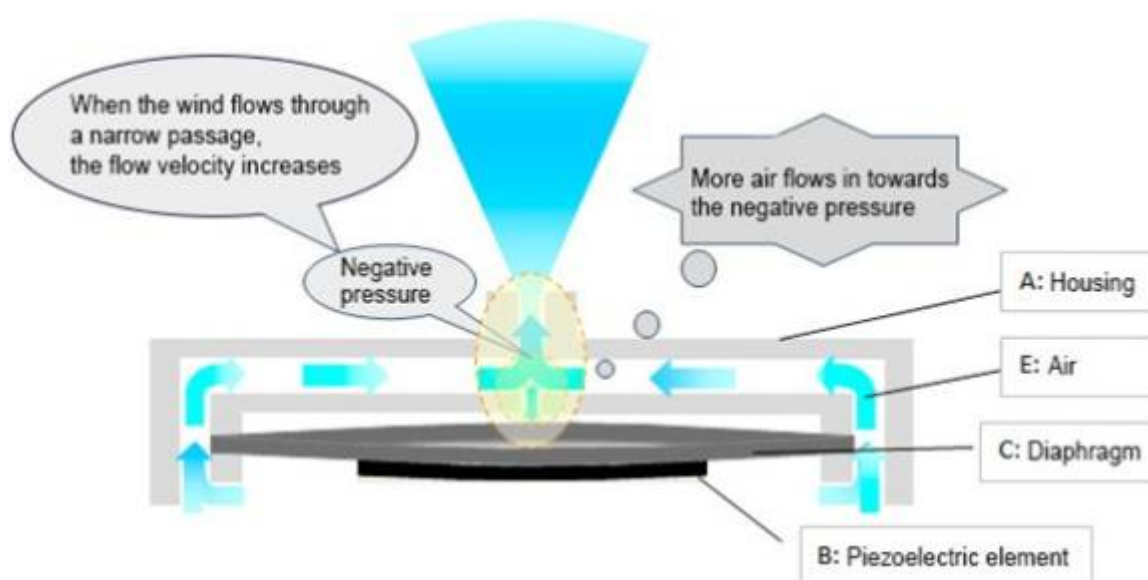

Figure 10: Working Principle of a Piezoelectric Microblower

2.6 Power source of propulsion

A blimp, it is only a gas known as “lighter than air” enclosed in an enclosure to which we attach ways of propulsion and manoeuvrability. Unlike aircraft, blimps do not require motorization to provide lift.

Motorization is indeed the key to blimp safety. The vast majority of blimps are powered by propeller engines. The engines used are most often thermal, but more and more blimps are propelled by electric motors powered by batteries, photovoltaic panels, possibly by wind turbines, but also by fuel cell engines. The fuel cell consumes hydrogen and delivers an output voltage that powers the electric motors.

2.6.1 Solar-powered blimp

The project Sol'R figure 11 was started in 2008 as a result of the efforts of three engineering students who met blimp enthusiast Stéphane Rousson. One hundred years after Louis Blériot crossed the English Channel, this initiative intends to fly across it in spite of the weather in an energy- and pollution-free manner. The panels used to construct this blimp are manufactured by Global Solar and sold by Euro-Line Inc. They have the benefit of being flexible, light, and easily detachable, yielding 6 %. The 2.4 kW of solar power gathered powers an electric motor hidden behind the piloting nacelle, which has two two-bladed propellers.



Figure 11: Blimp from Sol'R project [Mike Chino, 2010]

2.6.2 Wind-powered blimp

A sail balloon trip covering 150 miles from southern France to Corsica is now being planned. High flyer Stéphane Rousson wants to fly Zeppy 3 over a section of the Mediterranean Sea using nothing but the wind and a curved carbon foil designed after Didier Costes' "chien de mer" figure 12. 200 cubic meters of helium are contained within the 65.6 feet long by 16.4 feet broad Zeppy 3 that was on exhibit at Le Bourget in France. The curving carbon foil skimming the water's surface will be connected to the pilot's cradle by an adjustable cable that can range in length from slightly over 65 feet to 164 feet. Once the airship is stabilized in the water by "the chien de mer", it will behave like a large sail and be able to fly head to wind at up to twice the speed of the wind.

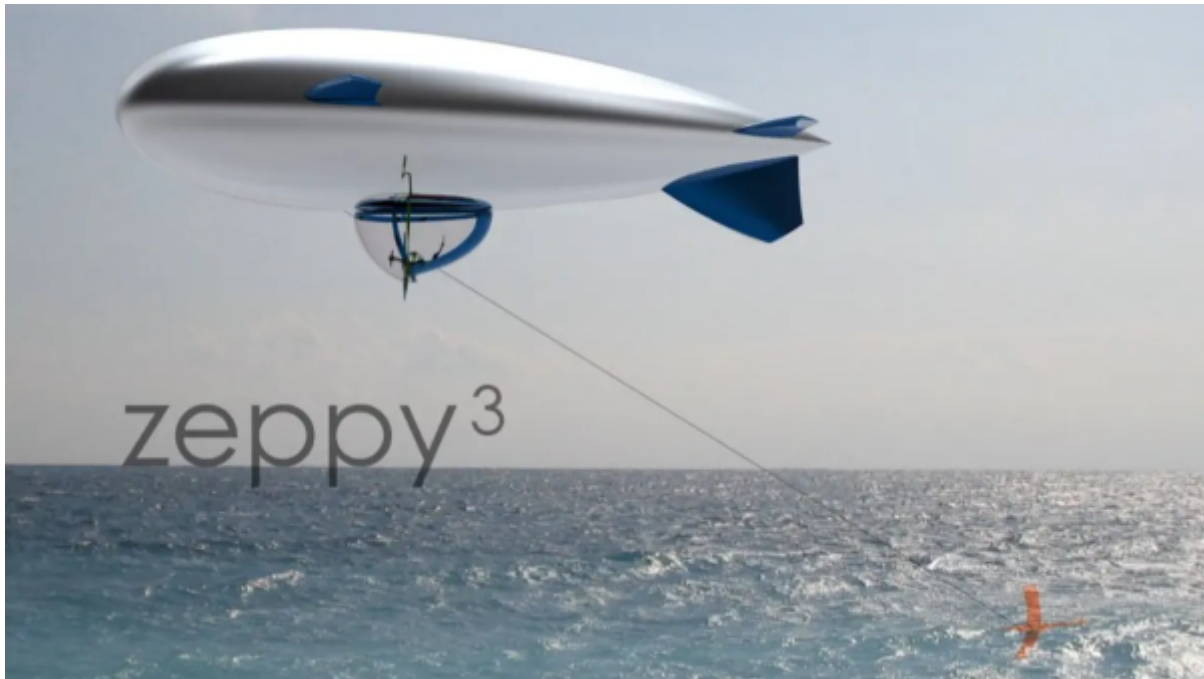

Figure 12: Blimp from Sol'R project [Paul Ridden, 2010]

2.6.3 Hydrogen-powered blimp

The H2 Clipper is a 1 000-foot long dirigible that can carry 125 to 200 tons and take up liquid hydrogen at a temperature of 423.4 °F from locations where it can be produced affordably using renewable electricity, such as the Middle East, the Sahara, and offshore wind farms in the North Sea. The hydrogen is then cooled to a liquid state and placed into an airship that can transport it to distribution and storage centres in consumer markets. Because gaseous hydrogen is not sufficiently energy dense to be transported over long distances at a reasonable cost, the airship must carry liquid hydrogen.

Four side-mounted, six-bladed propellers and an eight-bladed stern propeller give the H2 Clipper propulsion figure 13. Electricity for the electric motors in each comes from PEM fuel cells that burn gaseous hydrogen, solar panels installed on top of the airship, or diesel generators that burn biofuels. 33 200 shaft hp are produced by all of the motors. However, the energy from the fuel cells is only used for accessories and not for propulsion.



Figure 13: Blimp from Sol'R project [\[Stephen J. Mraz, 2022\]](#)

2.7 Examples and applications of blimps

2.7.1 Military application

In history, we know of several cases of using airships for various purposes. One was the Tethered Aerostat [14](#), which was equipped with a radar system designed to provide low-level radar surveillance along the border between the United States and Mexico, the Straits of Florida, and the Caribbean in support of federal agencies involved in a national drug interception program. Also in Israel, experiments were conducted to create an airship to detect low-flying missiles. Airships in the military field were also used to support communications on the battlefields of Iraq and Afghanistan. They were a good alternative to expensive satellite systems. They were mainly used as tethered and autonomous platforms at high or low altitudes, as military communications transmitters.



Figure 14: Tethered Aerostat [\[Elizabeth Stoeckmann, 2017\]](#)

2.7.1.1 Current companies working with blimps - A-NSE

A-NSE is a company specializing in the design, manufacture and operation of airships and tethered balloons for civil and military missions requiring durability at altitude [15](#). The company has 2 main types of products; T-C60 tactical range for communications relay or optical surveillance missions and T-C350 fixed range for communications relay, optical and radar surveillance and electronic warfare missions.



Figure 15: A-NSE product [\[Mark Piesing, 2019\]](#)

2.7.1.2 Current companies working with blimps - Atlas, flying whales, hybrid air vehicle

The main goal of The Atlas company is to introduce airships into everyday life. They are to be an ecological alternative in the aviation industry, the very symbolic emission of poisonous coal is their main advantage. They appear in the form of viewing airships, for example, in the areas of national parks and historical buildings around the world thanks to the smooth and quiet flight they offer [16](#). It is also affordable thanks to its low exhaust emissions and environmentally friendly electric drive, which reduces operating costs.



Figure 16: Atlas product [\[Jake Epstein, 2021\]](#)

Atlas's flagship product [17](#) is to be airships for transporting large loads of up to 165 tons. Along with the many advantages of airships, such as the lack of the necessary landing infrastructure, it can land anywhere, in the desert, on water and even on ice, low-emission and environmentally friendly, it is a great threat to cargo planes, which burn huge amounts of fuel and leave a huge carbon footprint in

the transport industry.



Figure 17: Atlas second product [Murdo Morrison, 2020]

The British company hybrid air vehicle (HAV), laid out plans for a series of short-haul flights that would enable city hopping with a fraction of the carbon emissions of a conventional aeroplane. Proposed routes include: Liverpool – Belfast, Oslo – Stockholm, Barcelona – Palma. HAV claims that the carbon footprint for these flights will be less than a tenth of the same journey in a conventional plane.

Another company from France called flying whales want to use blimps for air cargo transport. Their vision is to design a transport solution that contributes:

- To the expansion of economic development in landlocked areas.
- To reduce the environmental impact of cargo transport.

Flying Whales is a French aeronautic start-up. It develops an environmentally-friendly airship, the LCA60T 18, designed to transport heavy loads, such as wood logs or specific gear like wind-turbine blades, without structure supports.



Figure 18: LCA60T [Miquel Ros, 2023]

But they are not the only one, also small start-ups till big aerospace giants are building modern zeppelins with a broad range of applications in mind. The blimp may offer viable alternatives and not just in passenger flights. Hybrid airships are touted for aid drops, search and rescue, eye-in-the-sky command centres and tourism. A major advantage of the blimp is that it requires little space to land and take off.

2.7.2 Communication application

In 2006, a former NASA executive launched his idea [19](#) to replace telecommunications towers with a fleet of airships floating in the sky. Replacing not very nice-looking towers was supposed to be an advantage for the view from which unattractive towers would disappear and beautiful flying balloons would appear. Airships were to be powered by solar energy, which would make them environmentally friendly. With no natural obstacles like trees or buildings, the signal would be better. The signal range would also increase. However, questions abounded about airships' resistance to stratospheric conditions. Many countries have expressed interest but no deals have been signed.



Figure 19: NASA idea [\[Alicia Chang, 2006\]](#)

2.8 Location of animals monitoring technologies

2.8.1 Radio Frequency Identification (RFID)

RFID tags (figure [20](#)) are discrete devices that are fastened to the animal's collar or ear. These tags produce a radio signal that RFID scanners positioned all throughout the farm may pick up. The technology can follow each animal's movements individually because each tag has a distinctive identification number.

- **Benefits:** Farmers can use RFID technology to track the whereabouts and trajectories of their livestock in real time. Farmers may be able to spot possible health problems, locate animals in distress or who have gone missing, and generally manage their farms better thanks to this.
- **Implementation:** In order to put an RFID system into action, farmers will need to place RFID readers all around their property and tag each animal with an RFID chip. Depending on the number of animals being tracked and the kind of RFID system being utilized, the cost of implementation may change.
- **Challenges:** Maintaining the tags' attachment to the animals is one difficulty in employing RFID technology for animal monitoring. Moreover, RFID scanners may not be able to identify tags in all sections of the farm due to their restricted range.

In general, RFID technology can be a useful tool for tracking the whereabouts and motions of agricultural animals. It can assist farmers in enhancing their management and animal health

procedures with effective execution.



Figure 20: RFID chip [Roger, 2020]

2.8.2 Global Positioning System (GPS)

The animal is fitted with GPS collars or tags (figure 21), which subsequently broadcast location information to a GPS receiver or satellite. Farmers may track the movement of the animal in real time by processing this data and displaying it on a map.

- Benefits: GPS technology can follow animals in places without RFID readers and provides more accurate location tracking than RFID. Also, it makes it possible for farmers to track livestock over bigger areas like meadows or fields. GPS collars or tags can be affixed to specific animals, although their implementation costs may be higher than those of RFID. Moreover, GPS may not be suited for animals that spend a lot of time in dense forests or other environments with poor sky view because it needs a clear line of sight to the sky to receive signals.
- Problems: GPS collars and tags need batteries, which must be replenished on a regular basis. The animals' added weight from the batteries may make them uncomfortable or have an impact on how they behave. Furthermore, trees, structures, and other barriers can interfere with GPS signals and reduce their accuracy.

In general, and especially for bigger or more remote locations, GPS technology can be a useful tool for tracking the whereabouts of animals on farms. When compared to alternative tracking systems, it may not be as suitable for all animals and settings, and its implementation costs may be higher.



Figure 21: GPS collar [Kaitlyn Wells, 2021]

2.8.3 Sensors

In order to track the animal's whereabouts, sensors are attached to it and make use of technologies like Bluetooth, Wi-Fi, and GPS (of which is described just before) as figure 22 shows. The central system receives the data from the sensors and processes and analyses it.

- **Benefits:** Sensor-based tracking systems can capture data on an animal's behaviour, such as grazing habits or activity levels, and can provide more specific information than RFID or GPS systems. Farmers that use this information can make better choices about the care of their animals and management techniques.
- **Implementation:** Collars or other wearable accessories can be used to attach sensors to animals. To gather more information on behaviour, they can also be included into the habitat of the animal, such as in feeders or water troughs.
- **Problems:** Sensors need batteries or other power sources, which might make the animal uncomfortable and add weight. In order to transfer data to the central system, they also need a dependable connection, which may not be available in remote or poorly connected places.

In general, sensor-based tracking systems can offer insightful information into animal behaviour and support farmers in making informed decisions. However, they might be more difficult to apply and might not be appropriate for all types of animals or habitats.



Figure 22: Sensors [Rajni Setia, 2020]

2.9 Drones

Aerial footage of the animals can be taken by flying drones over the farm that are fitted with cameras or other sensors (figure 23). The location, behaviour, and health of the animals may then be tracked by examining the video.

- **Benefits:** Drone-based monitoring is great for larger farms since it can efficiently and swiftly cover enormous regions. High-resolution photos and video can also be provided, which can be used to identify specific animals and spot any health problems.
- **Implementation:** A drone and a camera or other sensors are needed for drone-based monitoring. To operate the drone safely and successfully, the operator must also possess the requisite knowledge and experience. Also, local laws governing the usage of drones may differ and call for specific permits or licensing.

- Problems: Animals may become stressed and behave differently as a result of drone noise and disruption. In locations with dense foliage or other obstacles, they may not be able to see the animals well since they need a clean line of sight.

Overall, drone-based monitoring can offer useful information about management techniques and animal health, especially for larger farms. To ensure safe and ethical use, correct regulations and guidelines should be followed, and additional knowledge and resources may be needed for implementation.

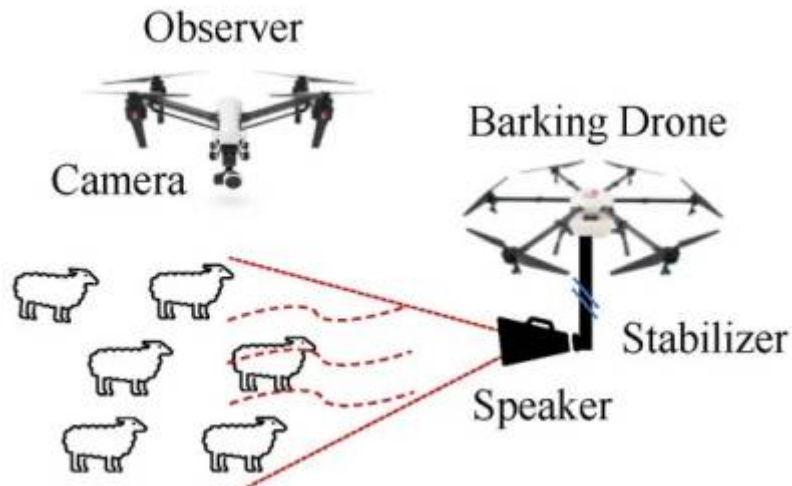

Figure 23: Drone [Xiaohui Li, Hailong Huang, Andrey V. Savkin, Jian Zhang, 2022]

2.10 Data Analytics

Data analytics is the step process like in figure 24 of gathering and evaluating information from a variety of sources, including sensors, RFID tags, GPS collars, and drone footage. The information is then utilized to spot patterns and trends in the movement, habitat, and state of health of animals.

- Benefits: By recognizing potential health issues or improving feeding and grazing schedules, data analytics can give farmers insightful knowledge about their animal populations. Additionally, it can aid farmers in making more educated choices regarding the management of their entire farm and the distribution of resources.
- Implementation: Using data analytics for animal monitoring may call for the use of specialist tools and data analysis know-how. Farmers might need to gather and combine information from numerous sources, like sensors or GPS collars, into a centralized system for analysis.
- Challenges: Ensuring the accuracy and quality of the data being collected is one difficulty with data analytics. When gathering data on specific animals, especially when using RFID or GPS tracking, farmers may also need to handle privacy concerns on other farms and houses.

Overall, data analytics can be a potent tool for keeping tabs on the whereabouts and conduct of farm animals. Farmers should be aware of privacy issues and data quality when gathering and analysing data, albeit it could need more money and knowledge for implementation.

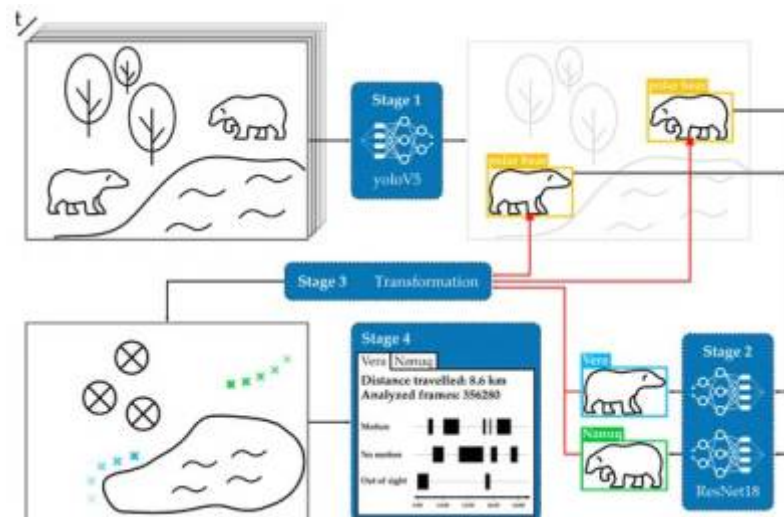

Figure 24: Data analysis graph [Matthias Zuerli, Philip Stoll, Ingrid Brehm, René Raab, Dario Zanca, Samira Kabri, Johanna Happold, Heiko Nille, Katharina Prechtel, Sophie Wuensch, Marie Krause, Stefan Seegerer, Lorenzo von Fersen, Bjoern Eskofier, 2022]

2.11 Vision-based detection technologies

There are numerous video monitoring technologies available today that provide a variety of features and functionality to meet varied surveillance demands. These technologies include:

2.11.1 Analog CCTV Cameras

The oldest and most fundamental type of security camera technology is analog CCTV. These cameras use parallel connections to transfer analog photos and video material to a monitor or recording device. In comparison to more modern camera technologies like IP cameras, analog CCTV cameras often have a lower resolution, which can lead to worse-quality video footage. They have fewer options for remote access because they need to be physically connected to a monitor or recording device.

But because it's so simple to use, dependable, and affordable, analog CCTV cameras are still frequently utilized in a variety of applications. Since the needs for surveillance are less complicated or demanding, they are frequently used in small firms, retail settings, and other commercial applications. Analog CCTV cameras are available in a range of sizes and styles, including dome, bullet, and box models. They also have a number of features, including vandal-resistant housings, motion sensing, and infrared night vision.

Some example where this type of camera is used:

- **Traffic Monitoring:** This camera can support law enforcement by monitoring traffic flow, spotting accidents, and capturing evidence.
- **Industrial applications:** To monitor production processes, maintain worker safety, and identify equipment failures, industrial settings frequently deploy analog CCTV cameras.
- **Schools & Universities:** To maintain student safety and deter vandalism and theft, analog CCTV cameras are frequently employed in schools and universities to monitor halls, parking lots, and other common areas.
- **Hospitality Sector:** To keep an eye on guests, deter crime, and protect the security of both staff

and customers, analog CCTV cameras are frequently employed in hotels, restaurants, and bars.

2.11.2 IP Cameras

Digital cameras with the ability to transmit audio and video over an IP network are referred to as IP cameras or network cameras. They can be connected to the internet or a local area network (LAN) and are mainly used for security and monitoring. IP cameras can be accessed remotely from any location with an internet connection and record high-quality video and audio data. When they detect motion or other events, they can also send warnings and notifications to a mobile device or email. They are therefore perfect for usage in residences, companies, and public spaces that need real-time monitoring and surveillance.

One of IP cameras' biggest benefits is their ease of integration into an existing network infrastructure, which makes them extremely scalable and affordable. They can be accessed using a web browser or a mobile app, and they can be connected to a network switch or router. Furthermore, they are able to be set up to record video to a network-attached storage (NAS) device or a cloud-based storage service. IP cameras can be equipped with a number of functions including night vision, motion detection, and audio recording. They are available in a range of different form factors including dome, bullet, and PTZ cameras. In order to offer a complete security solution, they can also be used in conjunction with other security systems like access control and alarm systems.

Some example where this type of camera is used:

- Homes: It can be used to monitor the inside as well as the outside of homes for security reasons.
- Businesses: They are frequently used in commercial settings to keep an eye on staff, prevent theft, and track customer traffic patterns.
- Public spaces: To keep an eye out for potential security concerns and to ensure safety, they are deployed in public spaces including parks, shopping malls, and transportation hubs.

2.11.3 Thermal Imaging Cameras

Infrared cameras, often known as thermal imaging cameras, are devices that record images by using infrared radiation as opposed to visible light. They use the changes in heat to make visuals while also detecting the temperature of the items. These cameras are widely used in a variety of fields, such as medicine, science, industry, and the military. Microbolometers, which are tiny sensors that detect the heat radiated by objects, are the foundation of the technology used in thermal imaging cameras. The information is then converted by the camera into a picture that can be viewed on a screen. Thermograms and infrared pictures are common names for the images created by thermal cameras.

The ability to identify heat signatures in complete darkness, through smoke, fog, and other visual obstructions is one of the key benefits of thermal imaging cameras. Also, because they can detect temperature differences as small as 0.1 degrees Celsius, they are valuable for spotting changes in machinery or other equipment that could be a sign of a problem. Overall, thermal imaging cameras are a helpful tool for many various businesses and fields due to their adaptability and capacity to detect heat signatures.

There are several fields where thermal cameras are used:

- Medical field: To detecting inflammation, identifying tumours, and monitoring blood flow.
- Industrial field: Used to identify areas of heat loss in buildings or to detect hot spots in electrical equipment, which may indicate a potential fire hazard.
- Military: Used for night vision and targeting systems.

2.11.4 PTZ cameras

PTZ cameras, also referred to as pan-tilt-zoom cameras, are a typical form of camera used for monitoring applications when a broad area of coverage is necessary. More control over the field of view is possible with PTZ cameras' ability to pan (rotate horizontally), tilt (rotate vertically), and zoom in or out. Depending on the application, PTZ cameras can be operated manually or automatically. With a joystick or other control device, a user can move and zoom the camera in manual mode. The camera can be configured to track a moving object using motion detection technology or to follow a predefined pattern in automatic mode.

PTZ cameras are frequently employed in security and surveillance applications, where they can be utilized to keep an eye on expansive areas like parking lots, malls, and public places. They can be used to record dynamic images of ongoing events in broadcast and video production as well. One of PTZ cameras' key benefits is their adaptability and capacity to capture a large amount of space with a single camera. Moreover, they provide a great degree of field-of-view control, enabling exact modifications to the camera's position and zoom level. However, they may cost more than other kinds of cameras, and additional hardware and administration software may be needed.

2.11.5 Dome cameras

Due to their dome-shaped housing, dome cameras are a particular kind of security camera. They are frequently used for both indoor and outdoor security applications due to their stealth and discreet nature, which makes them challenging to detect and tamper with. There are many different sizes and styles of dome cameras, including fixed, pan-tilt-zoom (PTZ), and vandal-proof models. They can be connected to a variety of recording and monitoring systems, including network video recorders (NVR) and digital video recorders, and they are also available in a range of resolutions, from standard definition to high definition (DVR).

The adaptability of dome cameras is one of their key benefits. They can be installed on walls, ceilings, and poles, and their design allows them to monitor a wide area without the need for many cameras. Several models also enable a variety of viewing angles, including 360-degree views, which can provide a location coverage. The durability of dome cameras is another benefit. Many designs are weatherproof and durable enough to survive challenging climates like rain, snow, and freezing temperatures. There are additional vandal-proof variants available, which include reinforced casings and hardened glass to withstand impact damage.

2.11.6 Bullet cameras

Popular surveillance camera models for outdoor security applications include bullet cameras. They are so called because they have a long, cylindrical shape that resembles a bullet. The small field of vision

and common mounting design of bullet cameras make them perfect for monitoring specialized areas like entrances, driveways, and parking lots.

One of its benefits is that bullet cameras are suitable for outdoor use and weather-resistant. They are frequently constructed from durable materials that can withstand exposure to extreme weather conditions, such as wind, rain, and heat. Bullet cameras typically come with a number of features that enhance their functionality and boost their effectiveness for security surveillance. A few typical bullet camera features are high-resolution video capture, night vision, motion detection, and remote access. Overall, bullet cameras are an useful and practical tool for keeping an eye on the outside of your property and can increase security.

2.12 Conclusion

In conclusion, the use of blimps for animal monitoring in agriculture offers several advantages and disadvantages. One of the key advantages is that blimps provide a non-invasive way to monitor animal movement and behaviour, which can help farmers and researchers gain valuable insights into animal welfare and productivity. Blimps are also relatively cost-effective compared to other methods such as GPS collars, and can cover large areas, which can save time and labour costs.

However, there are also some limitations to the use of blimps in agriculture. For example, blimps are limited by weather conditions and altitude restrictions, and may not be suitable for use in areas with high wind speeds or extreme weather conditions. Additionally, the cost of purchasing and operating a blimp can be prohibitive for smaller farms or research institutions.

Despite these limitations, there are several current applications of blimps in agriculture for animal monitoring. One such application is in monitoring grazing patterns, which can help farmers optimize their land use and prevent overgrazing. Blimps can also be used to identify animal health issues, such as lameness and assess the impact of environmental factors on animal behaviour. Furthermore, blimps can be used for animal population surveys, which can help researchers better understand the distribution and movement of animal populations in a particular area.

Overall, while the use of blimps for animal monitoring in agriculture is still in the early stages of development, it offers several potential advantages and has numerous applications. Further research and development in this field could lead to more widespread adoption of this technology and its integration into the agricultural industry.

3. Project Management

3.1 Scope

Effective project management is necessary for the development and launch of a sustainable outdoor blimp for agricultural usage. The primary project management steps—from conceptualisation to implementation and delivery—are intended to be summarised in this scope. Our project seeks to create a sustainable outdoor blimp that will assist big farmers with monitoring their animals. Farmers will be able to monitor their livestock from a distance thanks to the blimp's cameras and other

sensors. The farmer can view the animals using an app on their smartphone or tablet, where they can not only see the blimp but also view a live feed of the animals. We wanted to construct this airship and app with as little environmental impact as possible while still giving farmers a useful tool.

Throughout this scope, we will discuss the project management process in detail, including planning, budgeting, scheduling, risk management, and quality control. We will explore the challenges and opportunities associated with developing a sustainable outdoor blimp for agricultural use and how they impact the project management process. Additionally, we will examine the importance of stakeholder management, effective communication, and team building in ensuring the success of the project. By the end of this scope, readers will have a clear understanding of the key principles and best practices in project management, as well as a practical example of how they can be applied in the development of a sustainable outdoor blimp for agricultural use.

We will use a Work Breakdown Structure (WBS) to visualize the scope of our project. This tool provides a hierarchical and visual representation of the project deliverables, breaking them down into smaller, more manageable tasks. By creating a WBS, we will be able to identify all the necessary components of our project and ensure that each task is accounted for. You will find the WBS in figure 25.

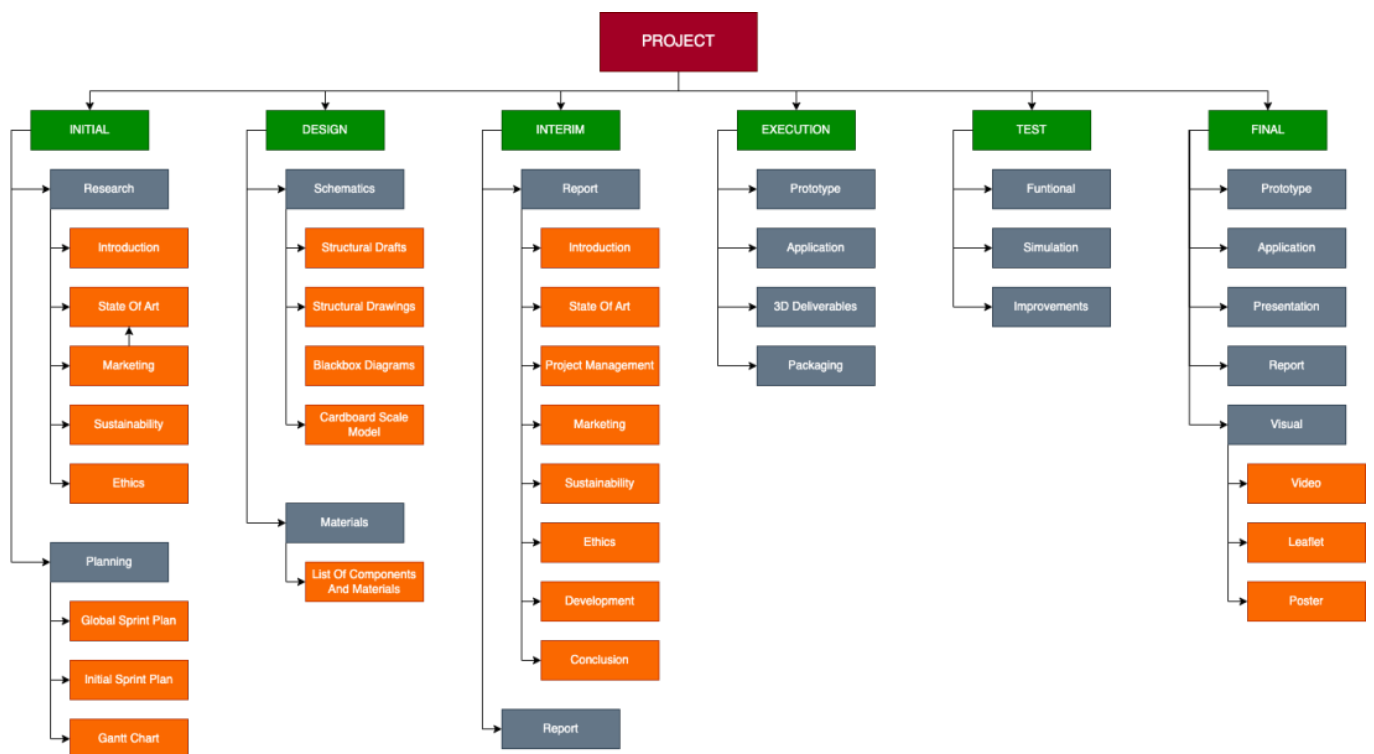

Figure 25: WBS Project

3.2 Time

Time management is crucial to a project's success because it ensures that it will be finished on schedule, within budget, and to the satisfaction of all stakeholders. Identification and prioritising of activities, resource allocation, the creation of timetables, and progress monitoring are all necessary components of effective time management. Without effective time management, projects may encounter delays, cost overruns, and other challenges that can result in decreased quality and stakeholder unhappiness. Additionally, effective time management enables project managers to predict and manage risks, make necessary changes to project plans, and keep lines of communication open with team members and stakeholders throughout the project's lifespan. Finally, time

management is essential to any project's success and helps to guarantee that objectives are met successfully and efficiently.

We must consider a variety of things during this project because EPS includes both the project and its deadline as well as the individual courses. To guarantee that we accomplish all of the goals within the given timeframe, we must carefully balance our resources and give enough time to each component.

In the list below you will find all the courses that take part during the EPS.

- Portuguese
- Marketing & Communication
- Project Management & Teamwork
- Energy & Sustainable Development
- Ethics & Deontology in Engineering

Table 5 presents all the deadlines that must be met to successfully complete the project.

Table 5: Project Deadlines

Date	Deadline
2023-02-26	Project proposal
2023-03-08	Project Backlog, Global Sprint Plan, Initial Sprint Plan and Gantt Chart
2023-03-15	The “black box” System Diagrams & Structural Drafts
2023-03-22	List of Components and Materials (what & quantity)
2023-03-29	The detailed System Schematics & Structural Drawings and the cardboard scale model of the structure
2023-04-16	Upload the Interim Report and Presentation
2023-04-20	Interim Presentation, Discussion and Peer, Teacher and Supervisor Feedbacks
2023-04-26	Upload the final List of Materials (local providers & price, including VAT and transportation) and 3D model video
2023-05-07	Upload refined Interim Report
2023-05-24	Upload packaging solution to Deliverables and Report
2023-06-31	Upload the results of the Functional Tests
2023-06-18	Upload the Final Report, Presentation, Video, Paper, Poster and Manual
2023-06-22	Final Presentation, Individual Discussion and Assessment
2023-06-27	<ol style="list-style-type: none"> 1. Update the wiki, report, paper with all suggested corrections 2. Place in the files section of the MS Teams channel of your team a folder with the refined deliverables (source + PDF) together with all code and drawings produced 3. Hand in to the EPS coordinator a printed copy of the refined report and poster
2023-06-29	<ol style="list-style-type: none"> 1. Hand in the prototype and user manual to the client 2. Receive the EPS@ISEP certificate 3. Bring typical food from your country

We have created a Gantt chart to help us properly manage our time. Including key information like task dependencies, start and finish dates, and other crucial information, this chart gives a thorough understanding of the project's timeline. By using this tool, we can more effectively keep track of our work, foresee any major obstacles, and make the required adjustments to keep the project on schedule. You will find this chart in figure 26.

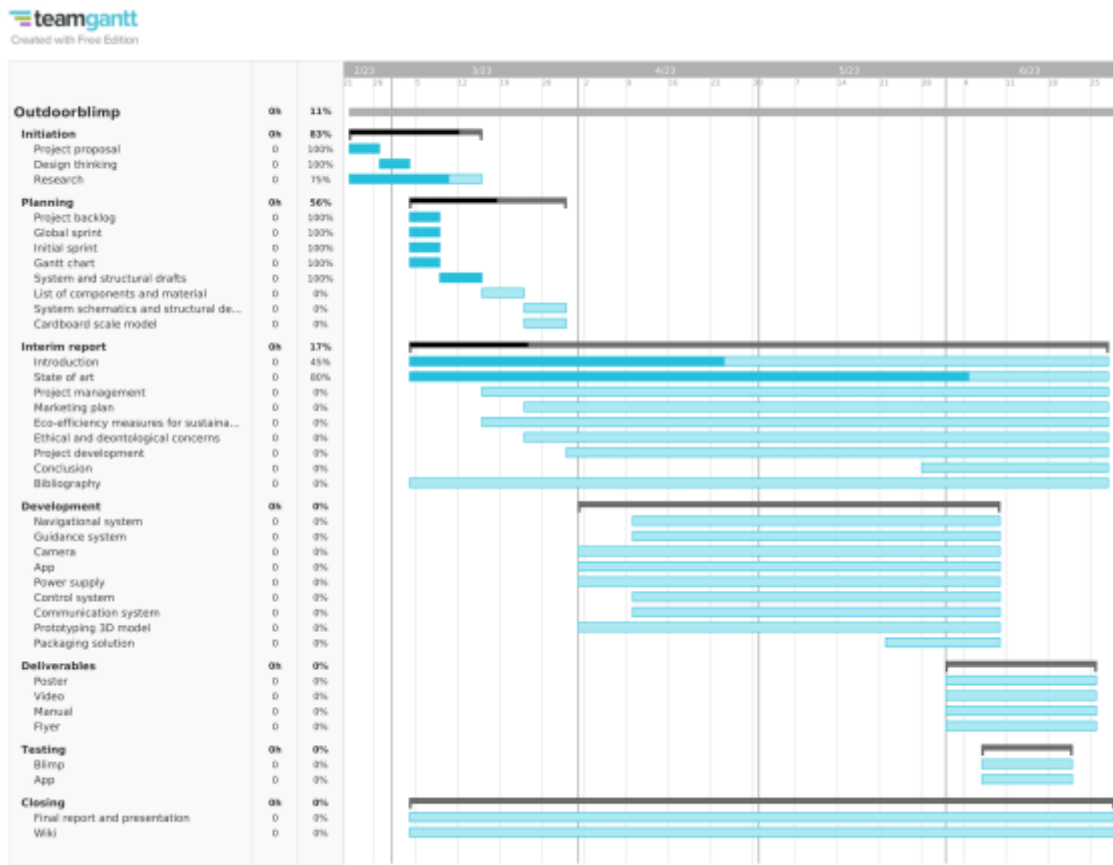

Figure 26: Gantt chart

3.3 Cost

Cost management is a crucial component of project management because it allows businesses to keep project costs within their approved spending limits. Without effective cost control, projects may exceed beyond their allocated budget, which could result in losses of funds, delays, and a decline in quality. Organisations can improve resource use, lower financial risks, and boost project profitability by managing project expenses. In addition to improving project outcomes, effective cost management enables project managers to make justified decisions based on accurate project cost data.

We have calculated the labour cost for this project based on the average entry-level engineering salary in the Porto region. We have assumed an entry-level engineer in Porto earns a gross monthly salary of 2000 €. The income tax rate for this level of income in Portugal is 14.5 %, which means an engineer would pay 290 € in income tax per month. In addition to income tax, the employee would also be required to make social security contributions, which are currently set at 11 % of their gross salary. In this case, the engineer would pay 220 € per month in social security contributions. Finally, the employer would also be required to make social security contributions at a rate of 23.75 % of the employee's gross salary, which would be 475 € per month in this example [Lara Silva, 2022].

The salary of each team member on a monthly and yearly basis is listed in Table 6. It is important to note that this calculation assumes a full workweek with a team of 5 members.

Table 6: Labor cost

Name	Salary (month)	Income tax (14.5 %)	Social security employee (11 %)	Social security employer (23.75 %)	Salary after income tax and social security (month)	Salary (year)
Sonia Gupta	2000 €	200 €	220 €	475 €	1015 €	12 180 €
Krijn Blommestijn	2000 €	200 €	220 €	475 €	1015 €	12 180 €
Kylian Dallongeville	2000 €	200 €	220 €	475 €	1015 €	12 180 €
Michał Piotr Mamos	2000 €	200 €	220 €	475 €	1015 €	1 2180 €
Maximilian Frieder Paulsen	2000€	200€	220€	475 €	1015 €	12 180 €
Total cost	10 000 €	1000 €	1100 €	2375 €	5075 €	60 900 €

For the prototype product we have received a budget of 100 €, the cost of the prototype is already set up in chapter 7.

3.4 Quality

What exactly is quality defined as? Understanding the meaning of this question is crucial for anyone working in product management. The following paragraph provides a general overview of what quality management entails:

Quality management is the process of ensuring that a product or service meets or exceeds the expectations and requirements of customers or stakeholders [Corporate Finance Institute, 2020]. It involves a systematic approach to identifying, measuring, and improving the quality of products and services. Quality management typically involves several key activities, including the ones that are important for the project are written down below:

1. Quality planning: this entails figuring out what the customer wants and expects. The problem definition includes a portion of this description. In order to monitor the farm and provide updates or alerts about what is happening there, our product assists the customer. The customer will now have the option to concentrate on other duties. In addition, the product must be self-sufficient and require little upkeep.
2. Quality control: This is the process of making sure that goods and services produced or delivered adhere to established quality standards. A list of demands is therefore made. Each demand has a test procedure and a number of weighting factors.
3. Continuous improvement: This entails regularly evaluating and enhancing procedures and goods to guarantee that they continue to satisfy or beyond the demands and expectations of customers.

Another method is the triple constraint, this is a concept in project management that refers to the three key parameters that must be managed in order to successfully complete a project: scope, time,

and cost [Harshal Shah, 2021]. In figure 27 you will find an overview.



Figure 27: Triple constraint [Rose Keefe, 2018]

1. Scope refers to the specific deliverables or outcomes that the project is intended to produce. It defines what will be done, how it will be done, and what will be included in the final product. Provide the customer with a product that saves him or her time, offers control and guarantees safety when something goes wrong. These are the three main tasks that the project must provide. These quality metrics are reviewed with the help of a program of demands. This is a guideline for the product design and a checklist for the quality.
2. Time refers to the duration of the project, including the deadlines for completing specific tasks and the overall project timeline. Managing time involves scheduling tasks and ensuring that the project stays on track to meet its deadlines. The project in total is one semester and that means that a good time schedule is needed in order to get all milestones done on time. Therefore we made a list of things that are needed to be done in the future. This list of tasks is divided into smaller tasks. Those tasks are divided in order to use the scrum method. In chapter 3.2 is an overview of the time schedule (Gantt chart) and the associated deadlines.
3. Cost refers to the resources required to complete the project, including materials, labour, and any other expenses associated with the project. Managing cost involves creating and managing a budget, monitoring expenses, and ensuring that the project is completed within the allocated resources. Because the product needs to exude quality and needs to be sustainable most of the budget will be spent on material and production costs. This includes a material that is durable, has a low environmental impact and has great aesthetics.

The focus must be that the cost of material and production are in comparison with the scope.

Successful project management requires careful management of all three parameters to ensure that the project is completed on time, within budget, and meets the desired scope and quality requirements.

3.5 People

A project involves a wide range of interests from numerous groups of individuals, or stakeholders, who have a big say in how it turns out. The stakeholders and their level of involvement have an important influence in whether a project succeeds or fails. The amount of information each stakeholder needs depends on how involved they are. The top internal and external stakeholders are listed in Table 7.

Table 7: Project stakeholders

Name	Role
Internal stakeholders	
Team members	Owners
Supervisors	Supervising the project development
Benedita Malheiro	EPS coordinator
ISEP	Main sponsor
Teachers	Providing resources and support
External stakeholders	
Customers	Target group
Suppliers	Provide goods
Competitors	Challenge and influence

3.6 Communications

Effective communication within a team is important for the successful completion of a project. Team members may work in bubbles, duplicating efforts or overlooking crucial information if there isn't clear and constant communication. Conflicts and misunderstandings may happen, which could slow down work and cause the project to be delayed. Team members can exchange ideas, worries, and updates by encouraging open communication within the group, which improves understanding of the objectives and specifications of the project. This can boost productivity, direct everyone's efforts toward a shared objective, and guarantee that the project is finished on time and within budget. In addition to encouraging positive team dynamics, effective team communication can increase team members' motivation and job satisfaction.

The two main forms of communication used by our team are oral and written. The majority of our weekly project meetings with supervisors and the in-person sessions we have after classes include oral communication. These meetings guarantee that everyone is on the same page and able to discuss crucial information in person. For immediate questions or concerns, we generally communicate in writing using a WhatsApp group we've set up. We also have a private team group where supervisors and teachers can reach us with any additional information or questions. This group can also be used as a backup for meetings if we are unable to attend in person. Our communication strategies have, on the whole, been successful in keeping everyone engaged and informed throughout the project.

3.7 Risk

Risks pose difficulties. They can cause delays, costs, missed goals, and even project failure if they are

not managed. However, when properly managed, they can present possibilities as well as a competitive advantage. A crucial component of all organizational activity is risk management. Become the risk specialist your firm needs by validating your abilities.

As a manager of a company it is important to follow the following guidelines:

- Identify problems before they occur
- Assess project risks
- Mitigate threats
- Maximize results and meet deadlines
- Leverage and even cause opportunities
- Save resources for your project and your organization

We employ the ranking hazards tool for our project. It assists in identifying which threat is really serious for the business and requires swift action. Table 8 displays the risk, the probability that it will occur, and the severity of the consequences if it does. The probability and impact values are expressed on a scale from 1 to 5.

Table 8: Risks

Nr.	Risk	Probability	Impact	Resolutions
1	Competition from drones that can nearly do the same tasks	4	5	Develop innovative technologies and monitor market trends
2	Handling the impacts of the the elements, including heat, rain, dust, wind, and UV exposure.	3	4	Use of water resistant materials, protective enclosures and consider backup power
3	A system that is to complex for the user	1	4	Prioritise features and functionalities. Focus on including essential features
4	Exceeding the budget	2	3	Monitoring and controlling the cost. Also have a clear project scope and requirements
5	Technical failures	3	3	Testing of the equipment and having regular maintenance checks
6	Errors in the software	2	2	Identifying the errors and solving them for the future
7	False alar s	1	3	False alarms can be minimised by ensuring that sensors are calibrated correctly and data is accurately interpreted

3.8 Procurement

The act of acquiring products, services, or works from an outside source is known as procurement. This is usually done through negotiation or a competitive bidding procedure. Getting the required goods or services at the best price, in the appropriate amount, at the right time, and through a reputable provider is the aim of procurement.

To guarantee that you obtain the best value for your money and to help you save time and money,

it's crucial to establish a procurement plan. Businesses have a wide range of strategies at their disposal. The kind of products or services required, the size of the company, and the budget all play a role in selecting the best one

Green purchasing will make up the majority of the procurement approach for the blimp project. This tactic emphasizes choosing products and services that have little negative influence on the environment. In the first place, practically all materials and components are bought locally in Europe. The product's used materials are either recycled through another process or emit less pollution. By doing this, Animo aims to make a difference to a more sustainable world.

3.9 Stakeholders Management

A stakeholder is a party with an interest in a business who has the potential to influence or be affected by it. They may be either internal or external to the company. Internal stakeholders are those who have a direct interest in a firm, for example through employment, ownership, or investment. External stakeholders are those who don't work for a company directly but are still impacted by its decisions and results. Suppliers, borrowers, and government agencies are all regarded as external stakeholders [\[Jason Fernando, 2023\]](#).

Stakeholder management is a method of project management that involves controlling the demands and expectations of all internal and external parties engaged in a project. To accomplish this, project managers must develop a stakeholder management strategy, a crucial project management document outlining the stakeholder management techniques to be used throughout the project. To understand stakeholders' influence and involvement and their impact on the project or business, stakeholder analysis is conducted to identify and evaluate the interests, expectations, and concerns of all stakeholders involved. You can find our stakeholder analysis in Table 9 [\[Manager Project, 2023\]](#).

Table 9: Stakeholder analysis

Stakeholder	Role	Interest (1-5)	Influence (1-5)
Team members	Development	5	5
Supervisors	Give feedback and guidance	5	3
Benedita Malheiro	Give feedback and guidance	5	4
ISEP	Provide money	3	4
Teachers	Give support and knowledge	4	3
Customers	Using the product	4	5
Suppliers	Providing supplies	1	3
Competitors	Competing	2	2

To help visualise the stakeholders we have created a graph called a stakeholder map. Our stakeholders should be mapped out so that we can better understand who they are, what they want, and how to involve them in the product development process. With this data, we can create a communication and engagement strategy that satisfies everyone's needs and helps in more effectively managing stakeholder expectations. The graph is divided into 4 quadrants: keep satisfied, manage closely, monitor and keep informed [\[Bryan Kitch, 2023\]](#). You can find the the graph in figure 28.

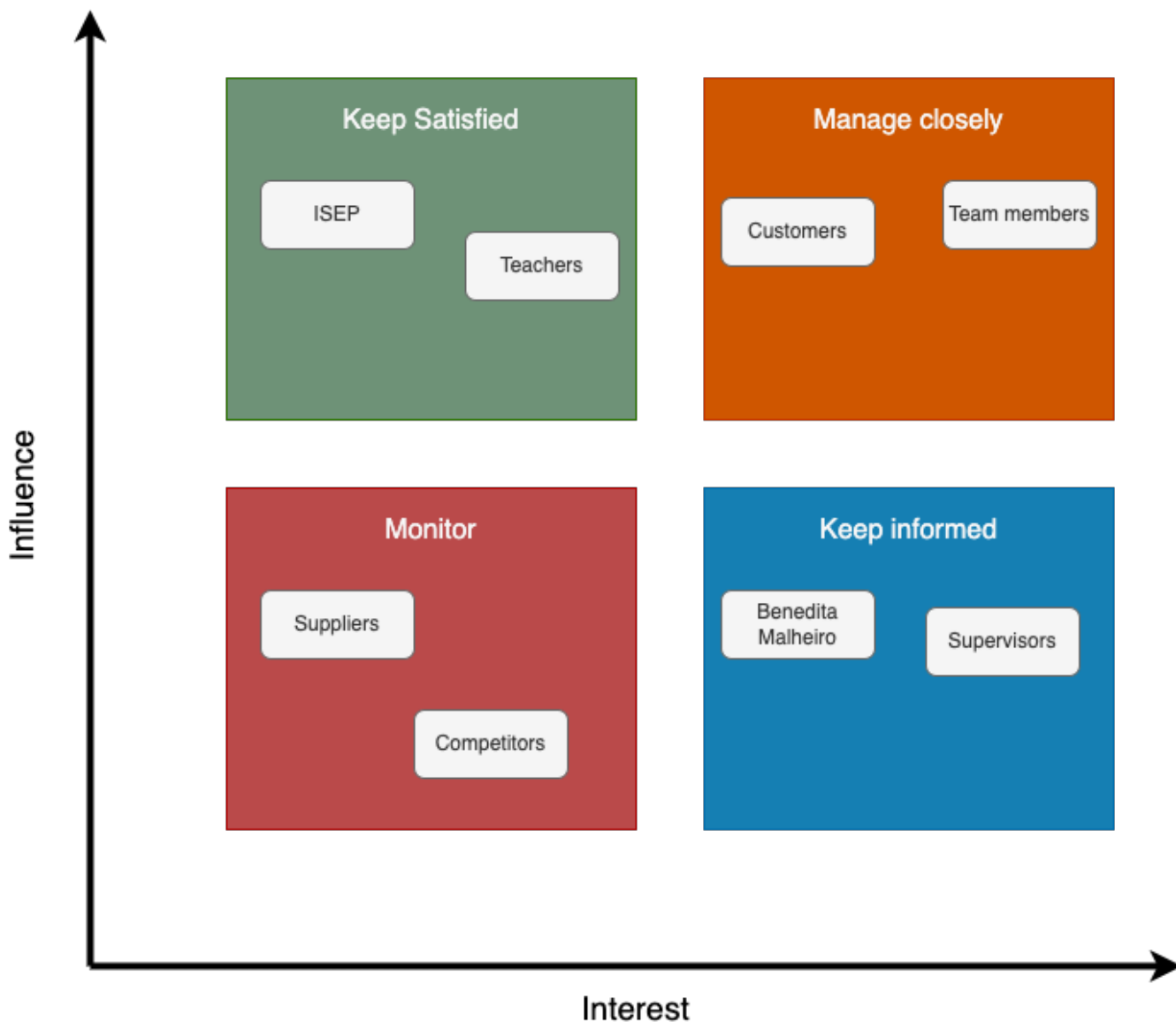

Figure 28: Stakeholders map

3.10 Project Plan

Our global sprint plan for this project consists of 1-week sprints, and it is available here for your reference in Table 10.

Table 10: Global Sprint Plan

Sprint	Start	Finish
1	22/02/2023	01/03/2023
2	02/03/2023	08/03/2023
3	09/03/2023	15/03/2023
4	16/03/2023	22/03/2023
5	23/03/2023	29/03/2023
6	30/03/2023	05/04/2023
7	06/04/2023	12/04/2023
8	13/04/2023	19/04/2023
9	20/04/2023	26/03/2023

Sprint	Start	Finish
10	27/04/2023	03/05/2023
11	04/05/2023	10/05/2023
12	11/05/2023	17/05/2023
13	18/05/2023	24/05/2023
14	25/05/2023	31/05/2023
15	01/06/2023	07/06/2023
16	08/06/2023	14/06/2023
17	15/06/2023	21/06/2023
18	22/06/2023	28/06/2023

Our project backlog includes a list of all the key milestones for our project, along with prioritized tasks and requirements. It serves as a reference point for the team to track progress and ensure that all the necessary work is being completed as planned. You can view them in [Table 11](#).

Table 11: Project Backlog

PBI	Title	Status
A	Project backlog	Done
B	Global and initial sprint plan	Done
C	Gantt chart	Done
D	Research	To do
E	State of art	To do
F	Project management	To do
G	System and structural drafts	To do
H	List of components and material	To do
I	System schematics and structural drawings	To do
J	Marketing plan	To do
K	Eco-efficiency measures for sustainability	To do
L	Ethical and deontological concerns	To do
M	Develop navigational system	To do
N	Develop guidance system	To do
O	Develop camera	To do
P	Develop app	To do
Q	Develop power supply	To do
R	Develop control system	To do
S	Develop communication system	To do
T	Interim report and presentation	To do
U	Packaging solution	To do
V	Videos	To do
W	Poster	To do
X	Manual	To do
Y	Testing	To do
Z	Final report and presentation	To do

3.11 Sprint Outcomes

As we are following the Scrum methodology and working with sprints of one week each, after every sprint, we have a sprint review. A sprint review is an informal meeting held at the end of a sprint, during which the team showcases what was accomplished. It is important because the sprint review allows the team to receive feedback from stakeholders and identify areas for improvement in the next sprint, making it a crucial component of the Scrum methodology. The tables below contain all sprint reviews [Nuclino, 2023].

Sprint 1 can be found in Table 12.

Table 12: Sprint 1 (22/02/2023 - 01/03/2023)

Product Backlog Item	Assignee	Planned Effort	Completed	Not Completed	Notes
Project Proposal	ALL	2 h	X		

Sprint 2 can be found in Table 13.

Table 13: Sprint 2 (02/03/2023 - 08/03/2023)

Product Backlog Item	Assignee	Planned Effort	Completed	Not Completed	Notes
Project backlog	ALL	6 h	X		
Global sprint plan	ALL	3 h	X		
Initial sprint plan	ALL	3 h	X		
Gantt chart	Sonia	6 h	X		

Sprint 3 can be found in Table 14.

Table 14: Sprint 3 (09/03/2023-15/03/2023)

Product Backlog Item	Assignee	Planned Effort	Completed	Not Completed	Notes
Introduction	Sonia & Krijn	3 h	X		
Research	All	8 h	X		
Blackbox	Max	2 h	X		
Structural drafts	Max	2 h	X		
System diagrams	Max	2 h	X		

Sprint 4 can be found in Table 15.

Table 15: Sprint 4 (16/03/2023-22/03/2023)

Product Backlog Item	Assignee	Planned Effort	Completed	Not Completed	Notes
----------------------	----------	----------------	-----------	---------------	-------

Product Backlog Item	Assignee	Planned Effort	Completed	Not Completed	Notes
List of components & materials	Max	5 h	X		
Eco-efficiency Measures for Sustainability	Michal	7 h	X		
State of Art	ALL	20 h	X		

Sprint 5 can be found in Table 16.

Table 16: Sprint 5 (23/03/2023 - 29/03/2023)

Product Backlog Item	Assignee	Planned Effort	Completed	Not Completed	Notes
Cardboard scale model	Kylian, Sonia & Krijn	5 h	X		
System Schematics & Structural Drawings	Max	5 h	X		

Sprint 6 can be found in Table 17.

Table 17: Sprint 6 (30/03/2023- 05/04/2023)

Product Backlog Item	Assignee	Planned Effort	Completed	Not Completed	Notes
Marketing presentation	All	1 h	X		
Marketing	All	10 h	X		

Sprint 7 can be found in table 18.

Table 18: Sprint 7 (06/04/2023 - 12/04/2023)

Product Backlog Item	Assignee	Planned Effort	Completed	Not Completed	Notes
Ethics	Michal	7 h	X		
Ethics presentation	All	1 h	X		

Sprint 8 can be found in Table 19.

Table 19: Sprint 8 (13/04/2023 - 19/04/2023)

Product Backlog Item	Assignee	Planned Effort	Completed	Not Completed	Notes
Mockup Mobile App	Sonia	7 h		X	
Power budget	Max	2 h	X		
Project management	Sonia & Krijn	5 h		X	

Product Backlog Item	Assignee	Planned Effort	Completed	Not Completed	Notes
Interim presentation	All	1 h		X	
Reread wiki	Sonia	2 h		X	
Ideation	Krijn	2 h		X	
Material and components	Max	2 h	X		
Packaging	Kylian	4 h	X		
Ethics & sustainability	Michal	5 h	X		
Software comparison & component diagram	Sonia	2 h	X		

Sprint 9 can be found in table [20](#).

Table 20: Sprint 9 (19/04/2023 - 26/04/2023)

Product Backlog Item	Assignee	Planned Effort	Completed	Not Completed	Notes
Feedbacks on interim Presentation	All	8 h	X		

Sprint 10 can be found in table [21](#).

Table 21: Sprint 10 (26/04/2023 - 03/05/2023)

Product Backlog Item	Assignee	Planned Effort	Completed	Not Completed	Notes
Report	All	5 h	X		

Sprint 11 can be found in table [22](#).

Table 22: Sprint 11 (10/05/2023 - 17/05/2023)

Product Backlog Item	Assignee	Planned Effort	Completed	Not Completed	Notes
Video	Krjin	3 h		X	
Prototype packaging	Kylian	6 h	X		
Solidworks	Max	6 h	X		

Sprint 12 can be found in table [23](#).

Table 23: Sprint 12 (17/05/2023 - 24/05/2023)

Product Backlog Item	Assignee	Planned Effort	Completed	Not Completed	Notes
Video	Krjin	2 h		X	
packaging materials	Kylian	3 h	X		

Product Backlog Item	Assignee	Planned Effort	Completed	Not Completed	Notes
Testing components	Max and Sonia	6 h	X		

Sprint 13 can be found in table [24](#).

Table 24: Sprint 13 (24/05/2023 - 31/05/2023)

Product Backlog Item	Assignee	Planned Effort	Completed	Not Completed	Notes
Video	Krjin	2 h		X	
Overleaf	Kylian	6 h		X	
Assembling components	Max and Sonia	6 h		X	

Sprint 14 can be found in table [25](#).

Table 25: Sprint 14 (31/05/2023 - 07/06/2023)

Product Backlog Item	Assignee	Planned Effort	Completed	Not Completed	Notes
Video	Krjin	2 h		X	
Overleaf and presentation	Kylian	3 h		X	
Programming system	Max	6 h		X	
Programming app	Sonia	6 h		X	

Sprint 15 can be found in table [26](#).

Table 26: Sprint 15 (07/06/2023 - 14/06/2023)

Product Backlog Item	Assignee	Planned Effort	Completed	Not Completed	Notes
Video and poster	Krjin	7 h	X		
Manual	Michal	6 h	X		
Overleaf and report	Kylian	4 h	X		
Programming system	Max and Sonia	6 h		X	
Programming app	Sonia	6 h		X	

3.12 Sprint Evaluations

Sprint retrospective is the final stage of the Scrum sprint cycle, during which the team reflect on the recently finished Sprint and come up with suggestions for how to make the following one better. The meeting's focus is on the team dynamics, methods, and tools that helped produce the planned increment rather than the actual product itself. The Scrum master often leads sprint retrospectives

and directs the meeting toward the following goals: identifying what went wrong, identifying what went right, identifying what can be improved, and nurturing a positive culture and environment [Wrike, 2023].

Sprint evaluation 1 can be found in Table 27.

Table 27: Sprint 1

Positive	Negative	Start doing	Stop doing	Keep doing
First time working together and the communication went well	None	None	None	Communicating well

Sprint evaluation 2 can be found in Table 28.

Table 28: Sprint 2

Positive	Negative	Start doing	Stop doing	Keep doing
The milestones were good	None	Meeting more	None	None

Sprint evaluation 3 can be found in Table 29.

Table 29: Sprint 3

Positive	Negative	Start doing	Stop doing	Keep doing
Team efforts	We had to change subject because we realised the previous topic was not achievable	None	Overthinking beyond our capacity	None

Sprint evaluation 4 can be found in Table 30.

Table 30: Sprint 4

Positive	Negative	Start doing	Stop doing	Keep doing
Came up with a name	None	Correcting reference mistakes in wiki	None	None

Sprint evaluation 5 can be found in Table 31.

Table 31: Sprint 5

Positive	Negative	Start doing	Stop doing	Keep doing
Worked really well together on making the card board model	System Schematics & Structural Drawings	Working together	None	Meeting and working after school

Sprint evaluation 6 can be found in Table 32.

Table 32: Sprint 6

Positive	Negative	Start doing	Stop doing	Keep doing
Marketing presentation went well	None	Practise more when there is a presentation	None	None

Sprint evaluation 7 can be found in Table 33.

Table 33: Sprint 7

Positive	Negative	Start doing	Stop doing	Keep doing
Communicated well during Easter	None	None	None	None

Sprint evaluation 8 can be found in Table 34.

Table 34: Sprint 8

Positive	Negative	Start doing	Stop doing	Keep doing
General design of the presentation is good	need to be more enthusiastic for some people	None	None	None

Sprint evaluation 9 can be found in Table 35.

Table 35: Sprint 9

Positive	Negative	Start doing	Stop doing	Keep doing
Everyone worked well on the feedbacks	None	None	None	None

Sprint evaluation 10 can be found in Table 36.

Table 36: Sprint 10

Positive	Negative	Start doing	Stop doing	Keep doing
None	None	None	None	None

Sprint evaluation 11 can be found in Table 37.

Table 37: Sprint 11

Positive	Negative	Start doing	Stop doing	Keep doing
Tasks were well divided	None	None	None	None

Sprint evaluation 12 can be found in Table 38.

Table 38: Sprint 12

Positive	Negative	Start doing	Stop doing	Keep doing
Good slides presentation	Marketing speech not enough confident	None	None	None

Sprint evaluation 13 can be found in Table 39.

Table 39: Sprint 13

Positive	Negative	Start doing	Stop doing	Keep doing
First move with the prototype		None	None	None

Sprint evaluation 14 can be found in Table 40.

Table 40: Sprint 14

Positive	Negative	Start doing	Stop doing	Keep doing
Tasks were well divided	Mistakes in components	None	None	None

Sprint evaluation 15 can be found in Table 41.

Table 41: Sprint 15

Positive	Negative	Start doing	Stop doing	Keep doing
All the objectives are realised	None	None	None	None

3.13 Conclusion

The success of a project depends on effective project management. By balancing scope, time, and resources, it offers a logical and organized methodology for planning, carrying out, and concluding projects. Stakeholder collaboration and communication, as well as a structured approach to project planning, execution, monitoring, and control, are all necessary for effective project management. Teams can manage risks, optimize resource allocation, and ensure that project objectives are met on schedule and within budget by implementing project management best practices. Goal-setting, resource management, risk reduction, and stakeholder communication are just a few of the essential components that make up project management. In order to accomplish particular project objectives, it also involves the use of processes, methods, knowledge, skills, and experience.

Project management provides a framework for identifying and managing project goals, requirements, resources, timelines, and risks, as well as for tracking progress and reporting on project status. Teams may make sure that projects are in line with company goals, satisfy the expectations of stakeholders, and add value to the firm by using effective project management techniques. Good project

management encourages teamwork, increases productivity, and improves project outcomes, enabling teams to successfully complete projects.

In the upcoming chapter, we will dive deep into the important role of marketing in ensuring the success of the project. Every successful business requires marketing since it entails advertising, selling, and distributing goods and services to consumers in order to satisfy their requirements and make money. Teams may boost visibility, reach their target audience, and establish a positive brand image by implementing efficient marketing tactics.

4. Marketing Plan

4.1 Introduction

In an organization, marketing's goal is to establish profitable relationships with the customers. The marketer's task is to determine the ideal target market, identify exciting business prospects, communicate the benefits of the product, and select a distribution strategy.

A marketing plan can act as a road map for managing, carrying out, and monitoring different marketing initiatives. It is a well-organized framework that brings all marketing initiatives together into a single, seamless operation. Knowing the exact target market for that market is made easier with a defined marketing strategy.

An outline of the blimp's marketing strategy may be found in this chapter. To obtain the data necessary to create a strategic plan, it begins with a market analysis. The SWOT analysis is then conducted to determine the internal and external factors that may present an opportunity or pose a threat. The strategy will then be decided when the brand and the position of the product have been defined and visualized. It's all about the four Ps: product, pricing, place, and promotion, or the marketing mix. The 4Ps provide insights into the ideal combination of elements to offer target customers value. These topics will be discussed in subsequent chapters.

4.2 Market Analysis

4.2.1 Research of our industry

4.2.1.1 Statistical Information

The value of Australia's livestock production as a whole was estimated by the Australian Bureau of Agricultural and Resource Economics and Sciences (ABARES) to be AUD 30.9 billion in 2020–21. Production of cattle, sheep, pigs, and poultry is included in this. The Australian cattle business is rapidly using technology for livestock monitoring, including electronic identity (eID) tags, GPS tracking, and remote sensing. Using these technologies can increase output, save expenses, and improve animal care. According to a MarketsandMarkets analysis, the global market for livestock

monitoring will increase by USD 2.5 billion by 2025, at a CAGR of 10.9 %, from USD 1.5 billion in 2020. The survey did not, however, include precise information about the Australian market. Agersens, eShepherd, and Connected Garden are just a few of the Australian businesses that provide solutions for monitoring livestock. These businesses offer a variety of services, including automated livestock weighing and sorting, GPS tracking and monitoring, and more. Overall, it is evident that there is significant interest in the use of technology to improve livestock production and animal welfare, and that there are a number of companies offering solutions in this space, even though I am unable to give you more detailed statistical information on the livestock monitoring industry in Australia beyond what has already been stated [[Meat, Livestock Australia, 2023](#)].

4.2.1.2 Size of the market in terms of the number of potential customers

The total quantity of livestock in Australia can be used to assess the size of the market in terms of the number of prospective clients for livestock monitoring systems. According to data from the Australian Bureau of Statistics (ABS), as of June 2020, there were approximately:

- 25.7 million cattle
- 66.1 million sheep
- 5.7 million pigs
- 5.5 million goats
- 678 million chickens

These figures imply that Australia has a sizable potential market for livestock monitoring products. Not all livestock producers, however, might be interested in or have the funding available to invest in such solutions, so it is important to keep that in mind. The type of livestock being monitored and the particular requirements of the producer may also have an impact on the potential market size. For instance, larger enterprises that handle a high number of animals may be more likely to spend money on cutting-edge monitoring technology than smaller operations. Overall, it is evident that there is a sizable potential market for the livestock monitoring sector in Australia, especially given the enormous quantity of cattle in the nation, even though I am unable to offer you an exact estimate of the number of possible clients [[Australian Bureau of Statistics, 2023](#)].

4.2.1.3 Revenue of the Industry

As there are no specialized industry reports or market research studies that concentrate only on the revenue created by this industry, it is difficult to ascertain the amount of money made by the livestock monitoring industry in Australia. In Australia, the agricultural technology (agtech) sector as a whole—which includes livestock monitoring as one of its subsectors—generates a lot of money, so we may examine that. AgFunder and the Future Food Systems Cooperative Research Centre (CRC) published a paper that estimates the agtech industry in Australia would produce about AUD 1.25 billion in revenue in 2020. This is an increase of 30 % from the previous year. But, in addition to livestock monitoring, this figure covers all agtech business segments, such as smart irrigation, precision agriculture, and digital marketplaces. The value of all cattle output in Australia was also predicted in a report by the Australian Bureau of Agricultural and Resource Economics and Sciences (ABARES) to be AUD 30.9 billion in 2020–21. The production of cattle, sheep, pigs, and poultry is included here, albeit it does not necessarily correspond to the money made by the livestock monitoring sector. Overall, it is evident that the agtech sector as a whole is experiencing significant

growth, and livestock monitoring is likely to be a significant contributor to this growth. However, I am unable to give you a precise estimate of the revenue generated by the livestock monitoring industry in Australia.

4.2.1.4 Standards by which companies and consumers operate

Animal welfare, food safety, and environmental sustainability are all ensured by a variety of industry regulations and norms that govern the livestock business in Australia. Businesses engaged in the livestock monitoring sector are expected to abide by these requirements as well as any applicable local, state, and federal laws. A code of conduct for livestock agents has been created by the Australian Livestock and Property Agents Association (ALPA) and includes guidelines for ethical behaviour and consideration of animal welfare. A set of industry guidelines for the marketing and sale of animals has also been produced by the Australian Livestock Marketers Association (ALMA). Moreover, a framework for guaranteeing the welfare of livestock is provided by the Australian Animal Welfare Standards and Guidelines for Cattle, Sheep, and Goats. This framework covers handling, processing, and transportation of animals. These guidelines cover a variety of subjects, including management of health and illness, housing and amenities, and feed and water. Aside from promoting best practices in animal welfare and sustainability, there are also industry associations, such as the Australian Livestock Monitoring Industry Association (ALMIA), that offer advice and support to businesses engaged in the livestock monitoring sector. Overall, although enterprises and consumers involved in the livestock industry in Australia are expected to adhere to industry standards and regulations, the exact criteria may differ depending on the particular subsector and type of animals involved.

4.2.1.5 External factors which have bearing on how businesses in this industry operate

Many outside variables can have a big impact on how Australian companies in the livestock monitoring sector run their operations. Among the most significant outside variables are:

- **Laws and regulations:** Australia has a number of rules and regulations covering many aspects of the livestock business, including animal care, food safety, and environmental sustainability. These rules must be followed by businesses in the livestock monitoring sector, which may have an impact on the development and application of monitoring solutions.
- **Modern technology** The livestock sector is fast changing thanks to technological advancements like sensors, remote monitoring, and artificial intelligence, which are opening up new prospects for enhancing animal welfare, effectiveness, and profitability. To remain competitive and satisfy changing client expectations, businesses in the livestock monitoring sector must keep up with technology advancements.
- **World events:** The cattle business can be significantly impacted by global events like pandemics, trade disputes, and climate change, which can modify consumer demand for products, disrupt supply chains, and change rules and policies.
- **Economic and social change:** The cattle sector can be significantly impacted by changes in economic and social factors, such as population increase, urbanization, and evolving food preferences. These changes can affect product demand, consumer behaviour, and market trends.

Generally, the Australian livestock monitoring industry operates in a complicated and quickly evolving

environment, with a variety of outside factors that may have an impact on how enterprises conduct their operations. Businesses that can successfully manage these outside influences and adjust to shifting circumstances are more likely to flourish and grow in this fast-paced market.

4.2.1.6 Opportunities to innovate the industry

Australia's livestock monitoring business offers chances for innovation in a number of different areas. These areas include, among others:

- New monitoring solutions for the livestock business are being developed as a result of advancements in sensor technology. There are opportunities to create new kinds of sensors that can monitor a larger range of factors, like animal behaviour and social interactions, and to enhance the precision and dependability of current sensors.
- Advanced analytics and machine learning can be used to better understand animal behaviour, spot patterns and trends, and create predictive models for disease outbreaks and other occurrences. This is made possible by the growing availability of data from sensors and other sources.
- Remote monitoring: Developments in communication technology are making it possible for farmers and producers to keep an eye on their livestock from a distance, which lowers labour costs and enhances animal welfare. There are opportunities to create new technologies that enable more thorough and accurate remote monitoring.
- Integration with other technologies: In order to develop more complete and effective farming systems, there are chances to link livestock monitoring technology with other agricultural technologies, such as precision agriculture and smart irrigation systems.
- Sustainability: As consumer concern about the environmental effects of livestock production rises, new opportunities for innovation in waste management, water conservation, and the creation of renewable energy are opening up.

Overall, the Australian livestock monitoring sector offers a variety of opportunities for innovation, driven by changes in customer tastes, technological advancements, and the need to enhance animal welfare and sustainability. Businesses who can successfully spot and seize these possibilities will probably be well-positioned for success in this fast-paced market.

4.2.2 Investigation of competitive landscape

The investigation of the competitive landscape has shown that it is very strongly characterized by indirect competitors. These have specialized primarily in video analysis and trackable collars. The use of blimps for the purpose of livestock monitoring has not yet appeared. In this sense, the most direct competitor is ZenaDrone Inc., since it uses a drone, i.e. also a UAV, for livestock monitoring tasks. The costs for the products could only be determined in the rarest of cases, since an official offer had to be obtained for this. However, it can be assumed that most of the products are in the higher price spheres.

4.2.2.1 Competitor Analysis

viso.ai (indirect Competitor)

Description of the company

Viso.ai is a Swiss technology firm that creates next-gen infrastructure for visual AI apps. To ease Computer Vision, they created a low-code / no-code AI vision platform. The business has offices in both Switzerland and the United States, where they have 11 - 50 employees. Viso.ai was established in 2017.

Target Customer

Industrial-scale livestock Farmers

Product

Viso.ai's animal monitoring application is designed to help farmers and livestock producers keep track of the health, location and well-being of their animals. The application uses artificial intelligence (AI) and machine learning (ML) algorithms to analyse data from sensors attached to the animals, such as accelerometers and temperature sensors. This data is then used to provide insights into the animals' behaviour, movement patterns, and physiological state.

Price

- subscription-based
- free demo available

Promotion

- LinkedIn
- Twitter

emphasize on:

- speed
- intelligence
- productivity
- easy to use

Place

- Demo on the website
- request an offer on the website

Strengths and Weaknesses

Strengths:

- Real-time monitoring: The Viso AI platform provides real-time monitoring of animal behaviour and health, allowing farmers to identify and address issues quickly.
- Accurate data analysis: The platform uses advanced algorithms and machine learning to analyse data from multiple sources, providing accurate and actionable insights.

- User-friendly interface: The platform has a user-friendly interface that allows farmers to easily access and interpret data.
- Customizable: The platform can be customized to meet the specific needs of different farms and livestock species.
- Non-invasive: The platform does not require any physical contact with the animals, reducing stress and discomfort.

Weaknesses:

- Cost: The Viso AI platform is likely to be more expensive than traditional monitoring methods, which could be a barrier for some farmers.
- Technical requirements: The platform requires a reliable internet connection and compatible hardware, which could be challenging in some rural areas.
- Limited scope: The platform focuses primarily on behaviour and health monitoring, and may not provide insights into other factors such as feed intake or reproductive health.

VisualCortex (indirect Competitor)

Description of the company

VisualCortex is a technology company that specializes in offering businesses with cutting-edge computer vision solutions. Their proprietary platform analyses and interprets visual data using sophisticated machine learning algorithms, allowing companies to gain insights into their operations and customer behaviour. VisualCortex is located in Australia, employs 11 - 50 people and was founded in 2022.

Target Customer

Industrial-scale livestock and crop Farmers

Product

VisualCortex's video analytics for agriculture and farming is a tool that utilizes computer vision technology to provide farmers with insights into their operations. This product helps farmers to increase efficiency, reduce costs, and improve crop yields. The video analytics solution is designed to work with existing surveillance cameras, providing real-time analysis of the video feeds. The system can detect and track objects such as people, animals, and vehicles, and can also monitor crop growth and health. The product offers a range of features including plant counting, weed detection, pest monitoring, and weather analysis. It can also help with irrigation management by detecting moisture levels in the soil and providing data-driven recommendations for watering.

Price

- subscriptions to their platform

Promotion

- LinkedIn
- Twitter
- YouTube

emphasize on:

- consistency
- intelligence

Place

- Demo on the website
- request an offer on the website
- They sell their product through resellers and distributors

Strengths and Weaknesses

Strengths:

- Accuracy: The Visual Cortex platform uses advanced computer vision and machine learning algorithms to accurately detect and monitor animal behaviour, even in challenging environments.
- Customization: The platform can be customized to meet the specific needs of different farms and livestock species.
- Non-invasive: The platform does not require any physical contact with the animals, reducing stress and discomfort.
- Real-time monitoring: The platform provides real-time monitoring of animal behaviour, allowing farmers to identify and address issues quickly.
- Easy integration: The platform can be easily integrated with existing farm management systems, allowing for seamless data sharing and analysis.

Weaknesses:

- Cost: The Visual Cortex platform is likely to be more expensive than traditional monitoring methods, which could be a barrier for some farmers.
- Technical requirements: The platform requires a reliable internet connection and compatible hardware, which could be challenging in some rural areas.
- Limited scope: The platform focuses primarily on animal behaviour monitoring, and may not provide insights into other factors such as feed intake or reproductive health.

digitanimal (indirect Competitor)

Description of the company

Digitanimal, a Spanish technology company launched in 2013, focuses on livestock industry solutions. By offering real-time tracking and monitoring capabilities, the business hopes to assist farmers in improving the efficiency of their operations and the welfare of their animals. Digitanimal creates solutions by combining technologies such as GPS, IoT, and machine learning. The business provides a variety of products and services, such as livestock tracking and monitoring, data analytics, and consulting. Digitanimal employs between 11 and 50 people.

Target Customer

mid- to large-sized livestock farmer

Product

Digitanimal is a digital solution designed to help livestock farmers manage their animals more efficiently. This product utilizes GPS and IoT technologies to provide real-time tracking and monitoring of livestock, allowing farmers to optimize their operations. The system consists of a collar that is attached to each animal, which contains a GPS tracker, temperature and activity sensors, and a communication module. The data collected by the collar is transmitted to a central platform where it is analysed using machine learning algorithms, providing insights into the animals' behaviour, health, and location. The product offers a range of features, including real-time tracking of animals, activity monitoring, and alert notifications for potential issues such as illness, injury, or theft. It can also help farmers to optimize feeding and watering schedules based on the animals' activity levels and location.

Price

- 189.95 € each
- one-time purchase

Promotion

- Facebook
- Twitter
- Instagram
- YouTube
- LinkedIn

emphasise on:

- time savings
- peace of mind

Place

- available on the website
- App on google play, Appstore + Web-Version

Strengths and Weaknesses

Strengths:

- Comprehensive monitoring: The Digitanimal platform provides real-time monitoring of multiple animal parameters, including location, behaviour, and vital signs, allowing farmers to gain a comprehensive understanding of their animals' health and well-being.
- Low cost: The platform is relatively low cost compared to other monitoring systems, making it accessible to a wide range of farmers.
- Easy to use: The platform is user-friendly, with an intuitive interface and easy installation process.
- Robust technology: The platform uses advanced technology, including GPS, IoT sensors, and AI algorithms, to provide accurate and reliable data.
- Customization: The platform can be customized to meet the specific needs of different farms and livestock species.

Weaknesses:

- Technical requirements: The platform requires a reliable internet connection and compatible hardware, which could be challenging in some rural areas.
 - Battery life: The battery life of the sensors may be limited, requiring regular recharging or replacement, which could be very challenging considering the fact that one has to do this for every device.
 - Data privacy: As with any technology that collects and analyses data, there may be concerns about data privacy and security. Farmers would need to ensure that the data collected by the platform is protected and used ethically.
 - Limited scope: The platform focuses primarily on animal monitoring and may not provide insights into other factors such as feed intake or reproductive health.
-

u-blox (indirect Competitor)

Description of the company

u-blox is a global technology business based in Switzerland that offers solutions for positioning, wireless communication, and IoT connectivity. The business, which was founded in 1997, has over 20 years of experience in the field and has become a partner for companies in a variety of sectors. It is a major competitor with 1281 (2022) [1] workers. The business provides GNSS modules, wireless communication modules, and IoT connectivity solutions, among other things. These devices are intended to provide dependable, high-performance connectivity for a variety of uses ranging from vehicle tracking to smart cities.

Target Customer

mid- to large-sized livestock farmer

Product

The IoT Tracking and Livestock Monitoring product offered by u-blox is an solution designed to help farmers optimize their livestock management practices. This product combines IoT and GPS technologies to provide real-time tracking and monitoring of livestock, enabling farmers to make data-driven decisions and improve their operations. The system consists of a collar that is attached to each animal, which contains a GPS tracker and a communication module. The data collected by the collar is transmitted to a central platform where it is analysed using machine learning algorithms, providing valuable insights into the animals' behaviour, health, and location. The product offers real-time tracking of animals, activity monitoring, and alert notifications for potential issues such as illness, injury, or theft. It can also help farmers to optimize feeding and watering schedules based on the animals' activity levels and location.

Price

no information available

Promotion

- Facebook
- Twitter
- Instagram
- YouTube
- LinkedIn

- GitHub

emphasize on:

- peace of mind
- low-power consumption
- globally deployable

Place

- Inquiry on website

Strengths and Weaknesses

Strengths:

- **Robust technology:** The platform uses GPS, LoRaWAN, and cellular connectivity to provide accurate and reliable data, ensuring farmers can easily track and monitor their animals.
- **User-friendly:** The platform is easy to install and use, and it provides intuitive interfaces that allow farmers to manage their animals from any device.
- **Battery life:** The devices have long battery life, which reduces maintenance and operational costs.
- **Real-time monitoring:** The platform provides real-time monitoring, allowing farmers to identify any changes in animal behaviour, location, and health.

Weaknesses:

- **Limited customization:** The platform may not be customized to meet the specific needs of different farms and livestock species, which may limit its usefulness in some situations.
- **Cost:** The platform may be costly compared to other monitoring solutions, making it less accessible to some farmers.

Digital Matter (indirect Competitor)

Description of the company

Digital Matter is a 51-200-person technology firm that specializes in the creation and development of IoT solutions. The firm was founded in 2000 and has since become a partner for businesses in a variety of industries across 120 countries. Digital Matter, based in Western Australia, provides a wide variety of products and services, including asset tracking, fleet management, and environmental monitoring solutions. These products are intended to provide dependable, high-performance connectivity for a variety of uses ranging from logistics and transportation to agriculture and building. Digital Matter has offices in Australia, Europe, South Africa and the United States.

Target Customer

mid- to large-sized livestock farmer

Product

Digital Matter's Livestock Tracking solution is a system designed to help farmers optimize their livestock management practices. The product combines GPS and IoT technologies to provide real-time

tracking and monitoring of livestock, enabling farmers to make data-driven decisions and improve their operations. The system consists of a collar that is attached to each animal, which contains a GPS tracker and a communication module. The data collected by the collar is transmitted to a central platform where it is analysed using machine learning algorithms, providing insights into the animals' behaviour, health, and location. The Livestock Tracking solution offers a range of features, including real-time tracking of animals, activity monitoring, and alert notifications for potential issues such as illness, injury, or theft. It can also help farmers to optimize feeding and watering schedules based on the animals' activity levels and location.

Price

- one-time purchase

Promotion

- LinkedIn
- Twitter

emphasize on:

- low-power
- future-proofness
- range and performance

Place

- available on the website
- over 500 resellers in the world

Strengths and Weaknesses

Strengths:

- **Versatility:** The platform provides tracking and monitoring solutions for various livestock animals, including cows, sheep, and goats.
- **Robust technology:** The platform uses GPS, LoRaWAN, and cellular connectivity to provide accurate and reliable data, ensuring farmers can easily track and monitor their animals.
- **Customization:** The platform allows customization to meet the specific needs of different farms and livestock species, providing a personalized experience for farmers.
- **User-friendly:** The platform is easy to install and use, and it provides intuitive interfaces that allow farmers to manage their animals from any device.
- **Real-time monitoring:** The platform provides real-time monitoring, allowing farmers to identify any changes in animal behaviour, location, and health.
- **Data analysis:** The platform provides advanced data analysis features, which may provide insights to improve animal welfare and productivity.

Weaknesses:

- **Cost:** The platform may be costly compared to other monitoring solutions, making it less accessible to some farmers.
- **Limited availability:** The platform may not be available in all regions, limiting its usefulness for farmers outside of those areas.
- **Limited integration:** The platform may have limited integration with other farming management

systems, making it challenging to integrate with existing farm systems.

Abeeway (indirect Competitor)

Description of the company

Abeeway is an IoT (Internet of Things) location monitoring solution provider. The business was founded in 2014, is headquartered in France, and employs between 11 and 50 people. Abeeway provides a variety of location tracking goods and services, such as asset tracking, people tracking, livestock tracking, and more. The solutions provided by Abeeway are intended to provide accurate and dependable location tracking in a variety of environments, including urban and rural regions. The company's products offer real-time tracking and monitoring data by combining GPS, LoRaWAN, and other wireless technologies. Abeeway offers a variety of value-added services, such as analytics and reporting tools, to help customers gain insights into their operations and improve their processes in addition to location tracking solutions. Abeeway works with companies in a variety of sectors, from logistics and transportation to agriculture and healthcare.

Target Customer

mid- to large-sized livestock farmer

Product

Abeeway's Tracking for Livestock and Farming is an innovative solution designed to help farmers optimize their livestock management practices. The product combines GPS and LoRaWAN technologies to provide real-time tracking and monitoring of livestock, enabling farmers to make data-driven decisions and improve their operations. The system consists of a collar that is attached to each animal, which contains a GPS tracker and a LoRaWAN communication module. The data collected by the collar is transmitted to a central platform where it is analysed using advanced algorithms, providing valuable insights into the animals' behaviour, health, and location. To keep track of the collar and therefore the livestock, Abeeway provides a ThingPark Location application called "Abeeway Device Manager", which is free to use.

Price

- one-time purchase
- 78 € - 395 €

Promotion

- ThingPark Market
- Twitter
- Youtube

emphasize on:

- light-weight
- precision
- long-lasting
- multi-mode

Place

- resellers and distributors (available on ThingPark Market, the largest IoT marketplace)

Strengths and Weaknesses

Strengths:

- **Highly Accurate:** The platform provides accurate location tracking of livestock with the help of GPS, LoRaWAN, and other wireless technologies.
- **Versatile:** The platform can be used to monitor and track livestock animals, such as cows, sheep, and goats, as well as other farm equipment and machinery.
- **Long Battery Life:** The devices have a long battery life, which reduces the need for frequent maintenance and operational costs.
- **User-Friendly:** The platform is easy to install and use, and it provides intuitive interfaces that allow farmers to manage their animals from any device.
- **Customizable:** The platform allows customization to meet the specific needs of different farms and livestock species, providing a personalized experience for farmers.
- **Real-time Monitoring:** The platform provides real-time monitoring, allowing farmers to identify any changes in animal behaviour, location, and health.

Weaknesses:

- **Cost:** The platform may be costly compared to other monitoring solutions, making it less accessible to some farmers.
- **Limited integration:** The platform may have limited integration with other farming management systems, making it challenging to integrate with existing farm systems.
- **Limited availability:** The platform may not be available in all regions, limiting its usefulness for farmers outside of those areas.
- **Limited Data Analytics:** The platform provides limited data analytics features, which may limit its usefulness for farmers who want to use data to improve animal welfare and productivity.

ZenaDrone (indirect Competitor)

Description of the company

ZenaDrone Inc. is a technology firm that specializes in the creation of autonomous aerial solutions for a variety of uses such as agriculture, surveying, and inspections. The ZenaDrone 1000 is the company's flagship product, and it is designed to be versatile, robust, and simple to use. The Intention behind the Invention of the ZenaDrone 1000 was to revolutionize the farming sector. The company is based in Dublin, was founded in 2010 and currently employs 2 - 10 people.

Target Customer

- Livestock and crop farmers
- Military
- companies with inspection tasks

Product

The ZenaDrone 1000 is a state-of-the-art UAV (unmanned aerial vehicle) that is equipped with

advanced sensors and cameras. The drone is capable of autonomous flight, which means it can operate without human intervention. This makes it an ideal solution for applications such as crop and livestock monitoring, mapping, and infrastructure inspections, where the ability to cover large areas quickly and efficiently is critical.

Price

- one-time purchase
- drone is rentable

Promotion

- Facebook
- Twitter
- LinkedIn
- YouTube

emphasize on:

- practicality
- innovation
- easy to understand and operate
- robust

Place

- Inquiry on website

Strengths and Weaknesses

Strengths:

- The Zenadrone Livestock Management product offers a comprehensive solution for livestock management, including real-time tracking and monitoring, geofencing, and data analytics.
- The product integrates with existing systems, such as Electronic Identification (EID) readers and third-party software platforms, to streamline data collection and analysis.
- The product is designed to be user-friendly, with a simple and intuitive interface that allows users to quickly access information and make informed decisions.

Weaknesses:

- The product's reliance on cellular networks for communication can be a weakness in areas with poor or unreliable network coverage.
- The cost of the product may be prohibitive for small-scale farmers or ranchers.
- The noise generated by the propellers of the drone might be frightening for nearby animals.
- The high power consumption, caused by the necessity to constantly create lift, lowers the actual flight time drastically.

4.2.3 Market gaps identification

A market gap refers to a discrepancy or unfulfilled need in a market that presents an opportunity for a new product, service, or business to address. It refers to a situation where there is a demand for a particular product or service, but the market does not currently provide an adequate solution.

Identifying a market gap is important for businesses because it allows them to create products or services that meet the needs of customers and fill the void in the market. By identifying a market gap, businesses can develop a competitive advantage by providing a unique solution that meets the specific needs of their target customers. It is a key component of market research and helps businesses to understand their customers' needs and preferences.

4.2.4 market gaps in agriculture

Then there is a market opportunity or unmet need that may be filled by creating and implementing brand-new goods or services, that circumstance is referred to as a “gap in the market” in the agriculture sector. In other words, it is a sector of the agriculture industry where there is a demand, but it is not being sufficiently met by the available goods or services.

Examples of market gaps in the agriculture industry may include:

1. Lack of access to modern farming technologies and equipment.
2. Inadequate distribution channels for agricultural products.
3. Limited availability of high-quality seeds and fertilizers.
4. Limited access to finance and credit for farmers.
5. Lack of transparency and traceability in the supply chain.

4.2.4.1 tasks that drones do in the agriculture market

Unmanned aerial vehicles, or drones, have a wide range of uses in agriculture. Drones are primarily used in agriculture for a variety of reasons, including:

1. **Crop monitoring:** Drones equipped with cameras and sensors can be used to capture high-resolution images of crops, which can be analysed to identify crop health, growth patterns, and stress levels. This information can help farmers make informed decisions about irrigation, fertilization, and pest control.
2. **Crop spraying:** Drones can be equipped with sprayers to apply pesticides, herbicides, and fertilizers precisely and efficiently. This reduces the amount of chemicals needed and minimizes environmental impact.
3. **Mapping and surveying:** Drones can create detailed 3D maps of fields and land, which can help farmers identify areas that need attention, such as drainage issues or soil erosion.
4. **Livestock management:** Drones can be used to monitor livestock and track their movement patterns. This can help farmers identify sick or injured animals and manage grazing patterns.

the use of drones in agriculture has the potential to improve farming operations' productivity, efficiency, and sustainability.

4.2.4.2 Australia

The focus on Australia as a market is due to its enormous potential for growth; yet, entering the market is only the first step; standing out requires more. Features for managing livestock in giant areas as represents figure 29 include the ability to track herds, diagnose diseases, use infrared imaging, GPS, and track lost calves. not enough to make them stand out. Because the product will be sold in Australia, a portion of the attention on identifying intriguing market gaps will be on issues that may be unique to that nation.

Australia's livestock business is not very diverse. Lamb and beef dominate the sector. Due to its lack of diversification, the business is less able to withstand outside shocks like a disease outbreak. The agriculture market would be interested in a product that might stop this from happening.



Figure 29: Australian landscape

4.2.4.3 Monitoring animals

Video monitoring can provide a wealth of information about animal behaviour, health, and activity levels. Some of the things that are possible to measure with video monitoring of animals include:

1. **Movement and Activity Levels:** Video monitoring can be used to track the movement and activity levels of animals, including the amount of time spent walking, resting, and eating.
2. **Social Interactions:** By monitoring the behaviour of animals in groups, video monitoring can provide insights into social dynamics, such as dominance hierarchies, grooming behaviour, and other forms of social interaction.
3. **Signs of Distress:** Video monitoring can be used to detect signs of distress or illness in animals, such as changes in posture, behaviour, or vocalizations.
4. **Eating and Drinking:** Video monitoring can be used to monitor feeding and drinking behaviour, including the amount and frequency of food and water consumption.
5. **Reproductive Behaviour:** Video monitoring can be used to monitor reproductive behaviour in animals, including mating behaviour and signs of pregnancy.
6. **Environmental Conditions:** Video monitoring can be used to monitor environmental conditions, such as temperature and humidity levels, in animal enclosures or pastures.

Video monitoring can be a valuable tool for assessing animal health and behaviour, and can help identify potential problems before they become serious.

Market gap conclusion

Farm animal monitoring is a market gap because traditional methods are time-consuming and often ineffective, and there is a significant demand for technology-driven solutions that can provide real-time data on animal health and behaviour. This presents opportunities for innovators to develop and bring new solutions to the market.

4.2.5 Target Market

4.2.5.1 Segment description

8 of the 10 largest farms being Australian, we have chosen to focus on animal farms in Australia. Indeed, the average surface of the 10 largest farms in Australia is 1 400 000 ha for an average of about 20 employees per company, which represents a very low number of employees. Indeed, the Quinyambie farm has a surface of 1 214 056 ha and counts 11 000 cattle for only 4 employees. They are this large because they live in a dry climate. This implies that there may not be as much greenery as there might be. As a result, stations must have a sizable quantity of land so that there is sufficient greenery to maintain even a typical number of cattle [[International Competence Center on Large Scale Agriculture, 2018](#)].

4.2.5.2 Daily lives

Over time, breeding facilities in Australia have modified how they operate. Every site serves as a labour station where the majority of mustering is still done using horses, dogs, and a saddle in order to complete a task. Nonetheless, an increasing number of stations are rounding up livestock with the aid of helicopters and motorcycles. Consequently, when the helicopter has collected livestock that would have taken days to gather on horseback, horses may assist and take over [[State Library of New South Wales, 2023](#)].

4.2.5.3 Problems and Challenges

Geographic isolation: Many of Australia's vast farms are located in remote, underdeveloped areas, making it challenging to access markets and services. Farmers may have to travel long distances to deliver their goods to markets or purchase supplies, which can drive up prices and affect profitability. Because of their seclusion, farmers and their families may struggle socially and emotionally, have trouble obtaining healthcare and other services, and feel cut off from the greater community. Some farmers have found innovative solutions to these issues, like forming cooperatives or working together to share resources and services [[Entegra Signature Structures, 2020](#)].

4.2.5.4 Features and benefits of blimps

Blimps would be low-noise and low-turbulence when they were afloat with helium and traveling with combustion engines and a green alternative. Another advantage is that the landing of these blimp-like devices wouldn't require any particular infrastructure. Indeed, our blimp will aim to monitor and analyse the behaviour and potential risks over a period around the livestock in the case of large stations in Australia sometimes difficult to access because of the distance.

4.2.5.5 Marketing messaging

The message that our company wishes to convey is that our system improves the working conditions of the farmers as well as the safety of the animals. High Capital Requirements: Building and launching outdoor blimps requires significant capital investments in equipment, technology, and skilled labour. This can make it difficult for new companies with limited resources to compete with established players in the market.

4.2.6 Entry Barriers

High Capital Requirements: Building and launching outdoor blimps requires significant capital investments in equipment, technology, and skilled labour. This can make it difficult for new companies with limited resources to compete with established players in the market. Regulatory Barriers: The government regulations surrounding the use of unmanned aerial vehicles (UAV) for commercial purposes can be complex and strict. Companies must obtain necessary permits and licenses to operate their equipment, and this process can be time-consuming and costly.

Established Competition: The market for outdoor blimps used for monitoring large cattle herds in Australia is already occupied by established companies that have invested in the necessary equipment, technology, and personnel. These companies have established relationships with their customers, which can make it difficult for new entrants to gain a foothold in the market.

Technological Expertise: Developing outdoor blimps that are effective and efficient at monitoring large cattle herds requires a high level of technological expertise. New entrants may not have the necessary knowledge and experience to compete with established companies.

Access to Distribution Channels: Established companies may have exclusive relationships with distribution channels, making it difficult for new companies to access the same channels and reach the same customer base.

Brand Recognition: Established companies have built brand recognition and reputation with their customers, which can make it challenging for new entrants to gain customer trust and market share.

4.2.7 PESTLE

The PESTEL study is a method for market and strategy analysis that enables us to identify the outside variables (opportunities and threats) that may have an impact on our business, either positively or negatively. It offers a broad perspective of the surroundings of our organization.

1. Political factors:

- The need for monitoring systems for large cow herds can also be influenced by the government's position on animal welfare and rules governing livestock agricultural techniques.

2. Economical Considerations:

- When determining whether to invest in monitoring systems, farmers and ranchers may consider the price of outdoor blimps and related equipment. The market for monitoring systems may be impacted by economic downturns since farmers may prioritize alternative investments to keep their businesses afloat.

3. Sociocultural Factors:

- Animal welfare is a prominent societal value in Australia, where cattle ranching is a significant sector. By keeping an eye on the health and safety of the cattle, outdoor blimps can help enhance animal welfare, which may encourage adoption. If the blimps are used to monitor ranchers or their lands, privacy issues can also arise.

4. Technical Factors:

- The efficiency of outdoor blimps for keeping an eye on sizable cattle herds may be impacted by developments in drone and blimp technology, including sensors and cameras. The utilization of outdoor blimps may also be impacted by the availability of trained operators and maintenance workers.

5. Legal Aspects:

- Laws governing the use of drones and blimps for business purposes may have an impact on whether monitoring systems are adopted.
- The use of outdoor blimps may also be influenced by their legal culpability for mishaps or damage they cause.

6. Environmental Factors:

- Outdoor blimp adoption may be influenced by how they will affect the environment, including noise pollution and potential wildlife disturbance. High winds or extremely hot or cold temperatures in Australia may have an impact on the performance of outdoor blimps.

Overall, a variety of factors, such as governmental restrictions, economic situations, societal values, technology improvements, legal frameworks, and environmental concerns, have an impact on the usage of outdoor blimps for monitoring animals in Australia.

4.2.8 Sales forecast

Australia's cattle industry could benefit from the use of surveillance blimps since they can be an efficient way to keep an eye on animals across vast and dispersed land regions. There may be a market for our business if we can produce a high-quality product and match the demand in the estimated 24,000 cattle farms that make up Australia [[Australian Bureau of Statistics, 2020](#)].

4.3 SWOT Analysis

After analysis, consultation and reflection, below is our SWOT analysis to determine the strengths, weaknesses, threats, and opportunities of our outdoor blimp in the context of farm monitoring. You can find our SWOT analysis in figure 30.



Figure 30: SWOT Analysis

4.4 Strategy

4.4.1 Strategic Objectives

The strategic goals of ANIMO could be:

To become the top producer of blimps in Australia for remote surveillance in big farms by offering top-

notch, cutting-edge, and dependable solutions that satisfy its clients' needs.

To make sure ANIMO continues to be a dependable and popular supplier in the industry by constantly innovating and improving its goods and services.

To build trusting relationships with key participants in the agricultural industry, such as farmers, equipment distributors, and research organisations, in order to learn more about consumer demands, market trends, and technological developments.

4.4.2 Segmentation and Targeting

ANIMO might divide the market into many categories depending on factors including farm size, livestock kind, and geography. Large farms with a high level of automation, a preference for cutting-edge technology, and a requirement for sophisticated surveillance systems to monitor their operations could be the target market.

4.4.3 Positioning

ANIMO may establish itself as a top supplier of cutting-edge, dependable, and user-friendly remote surveillance solutions for big farms that help clients run their operations more successfully and successfully. The business might emphasize its use of recyclable materials and renewable energy sources in the manufacturing process as a key distinction by emphasizing its commitment to sustainability. By providing tailored solutions that address the particular requirements of various consumer segments, ANIMO may further set itself apart from its competitors.

4.4.4 Marketing-Mix

The following could be part of the marketing mix for ANIMO:

Product: ANIMO may create a variety of blimps with cutting-edge features including high-definition cameras, infrared imaging, night vision, and real-time monitoring capabilities that are specifically made for remote surveillance in sizable farms. To make sure that its consumers are happy with their purchases, the business could also provide extra services like installation, maintenance, and technical support.

Price: By taking into account elements like production costs, market demand, and competition, ANIMO could set competitive prices for its products. Additionally, the business could provide discounts or package offers to clients who buy many blimps or take out long-term contracts.

Place: ANIMO could sell its goods through a number of methods, including direct sales, agreements with agricultural equipment suppliers, and internet markets. The business can also think about establishing a network of dealers or distributors to more effectively contact customers in various areas.

Promotion: To increase interest in ANIMO's goods and services, the company could use content

marketing, public relations, and advertising. The business might exhibit its products and interact with prospective clients through trade exhibitions, industry gatherings, and webinars. Social media platforms could be used by ANIMO to interact with its target market and increase brand recognition.

4.4.5 Brand

The three pillars of ANIMO's brand, innovation, dependability, and sustainability, might serve as its foundation. The business may create a brand identity that is friendly, competent, and customer-focused, reflecting its dedication to offering its clients the greatest options. Additionally, ANIMO may create a compelling brand identity that is present in all marketing materials, such as its website, social media accounts, advertisements, and packaging. To further solidify its dedication to sustainability, the corporation can think about collaborating with trade organizations or non-governmental organizations (NGOs) that support sustainable agricultural methods.

4.5 Marketing Programmes

4.5.1 Programmes

ANIMO's marketing initiatives may consist of the following:

Direct marketing: ANIMO might use phone calls, emails, and direct mail to reach potential customers. To increase the efficiency of its direct marketing initiatives, the business might also create mailing lists that are specifically targeted depending on farm size, region, and livestock kind.

Digital marketing: To reach potential clients, ANIMO could make use of digital channels like social media, search engine marketing, and display advertising. In order to inform clients about the advantages of its solutions and position itself as a thought leader in the field, the business might also provide content like blog posts, videos, and webinars.

Event marketing: To present its solutions and interact with potential consumers, ANIMO could take part in trade shows, industry gatherings, and agricultural fairs. To foster relationships with current consumers, the business might also host its own events, such as product launches and client appreciation days.

Marketing through referrals: ANIMO may use incentive plans like discounts or other benefits to entice current clients to refer business to the company. The business might also create a referral marketing plan that includes contacting pleased clients to get recommendations.

4.5.2 Budget

The size of the business, the level of competition, and the marketing objectives could all have an impact on ANIMO's marketing expenditure. ANIMO could divide its spending among various marketing avenues according to their prospective ROI. For instance, because digital marketing channels like

search engine optimization and social media advertising have a lower cost per acquisition than conventional marketing channels like TV and print advertising, the business may spend a larger budget to them.

4.5.3 Control

A number of measures, including website traffic, lead generation, and sales, could be used by ANIMO to assess the success of its marketing initiatives. In order to learn more about consumer happiness and enhance its marketing initiatives, the business could also use customer surveys and feedback. In order to monitor key performance metrics and modify its marketing approach as a result, ANIMO could set up a marketing dashboard. The business might assess its marketing strategies on a regular basis to find opportunities for development and implement the necessary changes.

4.6 Conclusion

The market analysis identifies a number of market inadequacies in the agricultural sector, including limited access to contemporary farming technologies and equipment, insufficient distribution channels for agricultural products, a lack of high-quality seeds and fertilizers, restricted access to credit and financing for farmers, and a lack of transparency and traceability in the supply chain. There are potential for creative solutions to fill these gaps. Additionally, crop monitoring, spraying, mapping, and animal management could all be done using drones to increase production, efficiency, and sustainability in agriculture. Large farms and a lack of diversification in Australia's cattle business create a niche market for creative solutions that can deal with problems like disease outbreaks. There is a market need for technology-driven solutions for farm animal monitoring, particularly in large cow herds where conventional approaches are time-consuming and unproductive. However, there may be obstacles to joining the market, such as high capital needs, complicated regulations, established rivalries, the demand for technological know-how, and lack of access to distribution channels. The adoption of monitoring systems like outdoor blimps can be influenced by a number of factors, including political, economic, sociocultural, technical, legal, and environmental ones, according to the PESTLE study. ANIMO's strategic goals include dominating the Australian blimp market, establishing credibility with influential industry figures, and focusing on the market segment of big farms with significant automation and surveillance requirements. The marketing mix for ANIMO includes content marketing, exhibitions, and social media promotions in addition to innovative products, competitive pricing, efficient distribution networks, and marketing campaigns. The core values of the ANIMO brand are innovation, dependability, and sustainability, and its marketing initiatives include direct marketing, collaborations with businesses or NGOs, and the use of digital platforms to connect with consumers.

5. Eco-efficiency Measures for Sustainability

5.1 Introduction

For thousands of years, geological resources have been used to produce food, build homes, provide transportation, and other necessities for people. Unfortunately, this overuse of resources has had a detrimental effect on the ecosystem, particularly in terms of pollution and resource depletion. Sustainable engineering is a concept that has arisen as a way to achieve economic growth needs while reducing adverse environmental effects. Designing products and procedures using sustainable development concepts is part of this strategy. In order to meet the demands of the current generation without compromising the ability of future generations to meet their own needs, sustainable development is a strategy. It entails striking a balance between development's economic, social, and environmental components. This harmony between human activity's impact on the environment, society, and economy is measured using indicators. The Happy Planet Index, for instance, is a sustainability statistic that assesses population well-being based on ecological impact and level of living. So, a technique that tries to maximize economic output while limiting the use of natural resources might be described as eco-efficient. Using techniques like waste management, energy efficiency, and water conservation are key components of this strategy. The life-cycle analysis approach, which examines the environmental impact of a product or process throughout its full life cycle, from manufacture to end-of-life, can be used to group all of these data. We have sustainability reports, which are records that detail a firm or organization's environmental, social, and economic performance, if we are more interested in the sustainable development component of the business than the product. As a result, all of these studies and analyses enable us to understand and appreciate the energy policy as a collection of policies and strategies designed to ensure efficient and sustainable energy production and usage. This covers measures like encouraging the use of renewable energy sources, cutting back on energy use, and lowering greenhouse gas emissions [[Santander Universidades, 2022](#)].

5.1.1 Environmental sustainability

To meet the demands of both the present and future generations without endangering the planet's health, environmental sustainability refers to the prudent and effective use of natural resources. It includes a wide range of methods and procedures meant to lessen adverse environmental effects and encourage long-term ecological equilibrium.

As the world's population continues to grow and the demand for natural resources rises, environmental sustainability is becoming a more crucial issue. Given that it acknowledges the interconnection of social, economic, and environmental systems, it is seen as being a crucial element of attaining sustainable development.

Many different parties are involved in efforts to sustain the environment, including people, companies, governments, and organizations. They can build a more sustainable future for our planet and its inhabitants by cooperating.

5.1.2 Economic sustainability

Economic sustainability is the capacity of an economy to sustain and enhance its citizens' quality of life over time. It entails maintaining a steady and predictable business climate while also ensuring that economic growth is inclusive, equitable, and environmentally responsible.

Due to the fact that it entails fostering innovation and entrepreneurship, creating sustainable

livelihoods, producing employment opportunities, and assuring long-term prosperity, economic sustainability is crucial for ensuring both. As economic sustainability is intertwined with social and environmental sustainability, it is also essential to attaining sustainable development.

A wide range of stakeholders, including governments, corporations, and civil society organizations, are involved in efforts to achieve economic sustainability. Together, they can build a more resilient economic system that fosters shared prosperity and safeguards the health of both people and the environment.

5.1.3 Social sustainability

Social sustainability is the capacity of a society to provide for the needs of its members in a fair, just, and inclusive manner while also fostering social resilience and long-term well-being. It covers a wide range of interrelated issues, such as human rights, social cohesion, cultural diversity, and access to necessities like food, shelter, healthcare, and education.

In order to achieve social sustainability, a comprehensive strategy that considers the social, economic, and environmental aspects of development is needed. This strategy must also entail the active involvement of a wide range of stakeholders, particularly underrepresented groups and local communities. It also necessitates a commitment to solving structural problems like inequality, prejudice, and poverty as well as an understanding of the connection between social, economic, and environmental elements.

In general, social sustainability is crucial to building a more just and equitable world where everyone has access to the opportunities and resources they need to prosper as well as a stronger and more resilient social fabric in communities.

5.2 Environmental

The use of blimps to convey surveillance equipment for monitoring rural regions is a growingly researched alternative. The environmental impact of these blimps on surrounding farmland must be considered, though. Noise, pollution, electromagnetic waves, failure and crash risks, as well as energy consumption, can all have an impact. To reduce these detrimental effects, suitable mitigation strategies must be implemented.

5.2.1 Noise level

The environmental impact of an eco-friendly blimp on farms can be significant, especially in terms of noise pollution. Blimps are often considered a more environmentally friendly alternative for monitoring rural areas, but it is important to note that they can generate a level of noise that can affect livestock in nearby farms. The level of noise generated by a blimp can vary depending on several factors such as size, speed, and altitude. Noise levels can reach approximately 80 decibels (dB) at a distance of 50 meters. To put this in perspective, the average sound level of a vacuum cleaner is around 70 dB, while that of a lawnmower is around 90 dB.

Animals' eating and sleeping schedules can be disturbed by noise, which can have a severe impact on their health and wellbeing. Due to their enhanced hearing abilities, animals like cows, horses, and pigs can be extremely sensitive to noise. Animals that are exposed to loud noises may experience worry, anxiety, and an accelerated heart rate. Their capacity to procreate, grow, and produce milk or meat may also be impacted by this.

Studies have shown that the impacts of blimp noise on farms can be reduced by using sound-absorbing materials for the airship's exterior coating and regulating flight hours to minimize impact on the animals. Flight hours can be planned to avoid critical times of the day for animals, such as feeding and resting. Additionally, sound-absorbing materials can be applied to the blimp's external surface and can significantly reduce the generated noise levels.

Using blimps to monitor rural regions, especially those close to farms, requires careful consideration of the acoustic impact. To reduce noise levels and avoid detrimental effects on animal health and welfare, appropriate mitigation measures should be put in place.

5.2.2 Pollution

Diesel, natural gas, and coal are just a few examples of the fossil fuels that are burned to create fine particles. The combustion of internal combustion engines, which are frequently employed for propulsion in the case of blimps, might result in the production of fine particles. Furthermore, friction and abrasion activities, such as the rubbing of propeller or turbine surfaces by moving engine elements, can also result in the production of fine particles.

The emission of air pollutants by blimps can have consequences on the health of living beings, particularly livestock and humans living near the farms overflown. Living things' lungs can be penetrated by the fine particles released by blimps, leading to respiratory issues such as asthma, chronic bronchitis, and decreased lung function. Moreover, these tiny particles have been linked to cardiovascular issues like heart disease and stroke. Moreover, the air pollutants that blimps release can harm nearby crops and ecosystems, reducing yields and upsetting the balance of the ecosystem.

It is possible to take a number of steps to lessen blimp emissions of atmospheric pollutants. First off, switching to cleaner engines like electric or hydrogen-powered ones can help cut down on emissions of fine particles and other air pollutants. Alternative propulsion technologies are being developed and might have a big impact on reducing emissions. Installing emission filters can also aid in capturing tiny particles and other air pollutants before they are released into the atmosphere. The engines themselves or the exhaust chimneys can both accommodate these filters. In conclusion, it is possible to greatly minimize the atmospheric pollutant emissions from blimps by combining these strategies, which can help lessen the negative effects of these vehicles on the environment on farms and in the air.

5.2.3 Environmental impact of a crash

Blimps can have a positive impact on the environment, but it's also vital to take into account the risks involved in a failure or crash of these blimps. Such occurrences can, in fact, have detrimental effects on the environment. First, materials used to build blimps, like metals and polymers, can be released into the environment in the event of a failure or accident. This may result in the discharge of

dangerous chemicals and the contaminating of nearby soil and water. Moreover, the environment and nearby species may sustain physical harm as a result of blimp debris. Broken electrical cables, for instance, can electrocute animals or start fires. Animals can also be hurt by glass and metal debris, which can potentially harm natural environments. Last but not least, blimp crash-related fires may have a significant negative impact on the environment. Flames have the potential to destroy nearby species as well as flora and natural ecosystems.

5.2.4 Effects of electromagnetic waves on animals

The use of blimps for remote monitoring may involve the emission of electromagnetic waves, which may have an impact on animals on surrounding farms. These electromagnetic waves are generated by the transmission and reception equipment installed on board the blimp to transmit and analyse the data collected. The effects of electromagnetic waves on animals, especially bees and birds, have been the subject of several research. These investigations have demonstrated that electromagnetic waves can interfere with these animals' normal behaviour, including their capacity for communication and navigation. Moreover, electromagnetic waves can harm their nervous and immunological systems, which could have a severe impact on their survival and general health. The amount of electromagnetic wave exposure, however, varies based on the distance between the animals and the blimp, as well as the strength of the transmission and reception equipment. As a result, it's critical to limit animal exposure to electromagnetic radiation as much as possible. To do this, make sure that blimps are operating at appropriately high altitudes.

To protect the safety of animals, it is crucial to take into account the proper distance between them and blimps that generate electromagnetic waves. Animal behaviour and health can be impacted by electromagnetic waves released by blimps, according to studies. It is advised to keep a minimal distance between animals and blimps in order to lessen this effect. To reduce negative effects on animal health, scientists advise keeping at least 100 meters between animals and blimps. Depending on the strength and frequency of the electromagnetic waves that the blimp emits, this may change.

It is crucial to remember that several circumstances, like an animal's age, state of health, and species, might affect how electromagnetic radiation affect them. As a result, it's critical to keep an eye out for unusual behaviour or indications of stress in animals.

5.3 Economical

When utilizing blimps to monitor livestock in Australia, there are a number of eco-efficiency methods that can be put in place to assure stability and lessen the influence on the environment. Here are a few ideas:

1. **Efficient use of energy:** Energy-saving components like LED lighting, solar panels, and low-energy motors can be added to blimps. As a result, the blimp will require less gasoline, resulting in a reduction in carbon emissions.
2. **Proper maintenance:** Blimps must undergo routine maintenance in order to run smoothly and prevent malfunctions or accidents. This covers routine maintenance, fixes, and part replacements.
3. **Use of eco-friendly materials:** Blimps can be built from environmentally friendly materials, such

recycled fabrics, which can lessen their influence on the environment.

4. **Reduced noise pollution:** Blimps should be made as quietly as possible to prevent disturbing wildlife and cattle. By switching from conventional combustion engines to electric motors, noise pollution can be reduced as well.

5. **Proper waste management:** To guarantee that any trash produced during monitoring activities is appropriately disposed of and does not cause pollution, the blimp should be fitted with waste disposal facilities.

6. **Monitoring of environmental impact:** It's critical to keep an eye on how blimp operations affect the environment to spot any areas that could use improvement. This entails keeping an eye on things like noise pollution, carbon emissions, and other potential environmental irritants.

7. **Cost-effective measures:** Further to environmental concerns, it's critical to think about the financial implications of blimp operations. The financial sustainability of blimp monitoring operations can be increased by cost-effective strategies such as smart route planning, resource optimization, and decreased downtime.

Blimps can be used to monitor livestock in a sustainable and profitable manner while limiting their environmental impact by putting these eco-efficiency measures into place [\[MasterClass, 2022\]](#).

5.4 Social

Here are some things to take into account regarding the sustainability and social aspects of blimps used to monitor livestock in Australia:

1. **Community engagement:** Local communities can develop a sense of ownership and responsibility for environmental and social sustainability by being involved in the monitoring process and educating them about the advantages of sustainable livestock management.

2. **Indigenous knowledge and practices:** Many Indigenous communities in Australia have traditional knowledge and practices related to livestock management that are sustainable and have been developed over generations. The monitoring process can be made more sustainable by incorporating these practices, which can also advance cultural heritage.

3. **Ethical treatment of livestock:** During the monitoring process, ensuring that cattle are treated humanely can help to advance social sustainability. This may entail employing non-intrusive monitoring techniques and making sure that animal welfare is taken into account.

4. **Local employment opportunities:** Giving locals work chances may have favourable societal effects. In addition to providing support services like data processing and reporting, this may entail training and employing locals to operate and maintain the blimps [\[Suzanne Vallance, Harvey C. Perkins, Jennifer E. Dixon, 2011\]](#).

5.5 Life Cycle Analysis

An extensive method for assessing the environmental impact of a process or product throughout the

course of its life cycle is the life cycle analysis (LCA). In the instance of an Australian blimp used for livestock monitoring, the LCA would entail evaluating the blimp's environmental impact from raw material extraction and production to use, maintenance, and ultimate disposal. The LCA procedure for a blimp monitoring cattle in Australia can be summarized as follows:

1. **Extraction and Manufacture of Raw Materials:** Several vendors will need to be found in order to obtain the fabrics, metals, and polymers needed to make the blimp. The effects of extracting these materials on the environment, including energy use, water use, and greenhouse gas emissions, will be evaluated. The actual manufacturing process will also be assessed, with attention paid to the amounts of water, energy, and waste produced.
2. **Transportation:** The blimp must be carried to the intended site after it has been made. The blimp's transportation will be assessed, with a focus on the energy use and emissions produced throughout that process.
3. **Use and Maintenance:** The blimp's environmental impact will be evaluated during its operation and maintenance phase. It will be assessed how much energy and pollutants, including gasoline usage, are used to run the blimp. The blimp's maintenance and repair, including the supplies utilized for repair and the waste produced during maintenance, will also be assessed.
4. **Disposal:** The airship must be disposed of once its useful life is through. The energy used, pollutants produced, and garbage produced during the disposal process will all be taken into consideration when assessing the environmental impact of disposing of the blimp.

Based on the findings of the LCA, suggestions can be made to lessen the impact of the blimp on the environment. These suggestions include using more environmentally friendly materials in the manufacturing process, increasing energy efficiency while in use, and recycling or repurposing the blimp once it has served its purpose [Jeroen B. Guinée, Reinout Heijungs, Gjalt Huppes, Alessandra Zamagni, Paolo Masoni, Roberto Buonamici, Tomas Ekvall, Tomas Rydberg, 2011].

5.6 Conclusion

In the context of eco-efficiency measures for sustainability, blimps offer a more ecologically friendly alternative to traditional methods for monitoring rural areas. However, in order to minimize the environmental impact of blimps on neighbouring farms and the surrounding ecosystem, it is important to consider the materials used in their construction, as well as their energy source and emissions. For instance, the blimp's external covering should be made of sustainable and sound-absorbing materials to reduce noise pollution. Additionally, the blimp should be equipped with an electric motor to eliminate emissions and minimize the use of fossil fuels. By implementing these measures, it is possible to significantly reduce the environmental harm caused by blimps in agriculture and their impact on the ecosystem.

6. Ethical and Deontological Concerns

6.1 Introduction

Australia's agricultural sector is vital to the nation's economy, and technology has become more and more critical in enhancing productivity and animal welfare. The use of blimps to watch over animals is one new technology. Blimps are self-propelled, lighter-than-air aircraft that are outfitted with cameras and sensors to keep an eye on the behaviour of animals and the surrounding environment. Although this technology has the potential to improve agriculture and animal welfare, it also presents moral questions. Privacy is one issue, as blimps have the capacity to take pictures that go beyond their intended use and may invade the privacy of farmers and nearby properties. The welfare of animals is also a problem, as using blimps may stress and disturb them. Concerns about data collection and possible information misuse are also ethical issues. We must establish a balance between the advantages of the technology and the ethical issues associated with its use in order to ensure the ethical use of blimp monitoring. This involves taking into account the effects on farmers, animals, locals, and the environment. To the advantage of all parties concerned, it is crucial to use this technology ethically and carefully [Prabhakar Krishnamurthy, 2011].

6.2 Engineering Ethics

This technology's designers and operators have a duty to make sure that the tools are constructed, operated, and used responsibly. They must weigh the technology's potential advantages and drawbacks, and take action to lessen any unfavourable effects. For instance, when designing the blimp's cameras and sensors, engineers must take into account the potential invasion of privacy for farmers and nearby properties. They must make sure that the device does not invade the privacy of others and only collects photographs and data relevant to monitoring livestock and environmental conditions. Engineers must also take animal welfare into account while utilizing blimps for monitoring. They must guarantee that the technology does not subject the animals to unnecessary stress or injury and that the data gathered is used to enhance their welfare. Engineers must also make sure that the information gathered is stored and used responsibly, and that it is not abused or misused for any actions that could harm people or violate their privacy. The use of blimps for livestock monitoring in Australia ultimately requires consideration of potential ethical and deontological issues in order to ensure that the technology is applied in a way that is both ethical and effective. This is required by engineering ethics [William M. Marcy, Jane B. Rathbun, 2017].

6.3 Sales and Marketing Ethics

Professionals in sales and marketing have an obligation to be open and truthful about the technological possibilities and constraints. They must avoid overstating the advantages of blimp surveillance and make sure that farmers and other stakeholders are fully aware of its ramifications. For instance, while promoting the use of blimps for livestock monitoring, sales and marketing professionals must be upfront about the possibility for privacy invasion and the potential effects on nearby properties. They have to make sure that the technology is used in a way that respects other people's privacy and doesn't come across as obtrusive or threatening. Additionally, sales and marketing experts need to make sure that the technology's advantages are accurately conveyed, as well as any potential risks or detrimental effects. They must be careful not to exaggerate the advantages of blimp monitoring or misinform farmers or other interested parties about its capabilities. Additionally, sales and marketing experts must make sure that the use of blimps for livestock

monitoring is not done in a way that exploits or injures animals. They must be transparent about the technology's advantages for animal welfare and make sure it is applied in a way that is kind to animals. In the end, sales and marketing ethics demand that people pushing for the use of blimps for livestock monitoring in Australia take into account any potential ethical or deontological issues and make sure the technology is marketed and sold in a way that is both ethical and effective [Pankaj M. Madhani, 2020].

6.4 Environmental Ethics

Environmental ethics are seriously questioned by Australia's use of a livestock monitoring airship. While the technology might help with better livestock management and monitoring, it also raises questions about how it will affect the environment and animal welfare. The potential effects of the blimp on the environment must be taken into account from the standpoint of environmental ethics. For instance, using drones or blimps to monitor cattle could raise noise pollution or disrupt the local fauna. Also, the creation and destruction of the blimp and the technology that goes along with it may have an impact on environmental degradation, such as through the emission of greenhouse gases or the generation of garbage. The usage of the blimp raises additional ethical questions due to its possible effects on animal welfare. Despite the possibility that technology can improve livestock management and monitoring, it is crucial to prevent undue stress or harm to the animals. This includes making sure the blimp isn't unduly intrusive, that it doesn't put the animals through unnecessary stress, and that it isn't utilized in place of basic animal husbandry procedures. Ultimately, the usage of a livestock surveillance blimp in Australia shows how important it is to carefully consider environmental ethics and animal welfare when creating new technologies and putting them into practice. It is crucial to make sure that such technologies are applied in a sustainable and moral manner and do not unnecessarily hurt the environment or the animals who are supposed to benefit from them [Fabio Zagonari, 2020].

6.5 Liability

Concerns over the effects of livestock production on the environment, animal welfare, and food safety have grown in recent years. Unmanned aerial vehicles (UAVs) have been used to monitor livestock by certain Australian farms in order to address these problems. The livestock monitoring blimp is one such remedy; it is a helium-filled balloon outfitted with cameras and other sensors that can deliver real-time data on the condition, activity, and location of cattle. Although this technology has the potential to enhance farm management and animal welfare, it also raises concerns about who will be held responsible for accidents or damage. The Civil Aviation Safety Rules (CASR) and the Civil Aviation Act 1988 govern liability for the use of UAVs in Australia. These regulations state that it is the duty of UAV operators to ensure the safe and legal operation of their aircraft, including adherence to all applicable rules and laws. Liability for damage or injuries caused by a livestock monitoring blimp would probably depend on a number of variables, such as what caused the incident, how much damage was done, and whether the operator was careless or negligent. For instance, the manufacturer may be responsible for any damages if the blimp malfunctioned as a result of a manufacturing flaw. The blimp's operator might be held accountable for any damages if they neglected to maintain or manage it correctly. Operators of livestock monitoring blimps should make sure they are appropriately licensed and trained, that their equipment is maintained, and that they abide by all applicable rules and regulations in order to reduce the risk of responsibility. Operators

should also think about getting insurance coverage to shield themselves from conceivable liability suits. Ultimately, even though using livestock monitoring blimps could help farmers and enhance animal welfare, it's critical for operators to be aware of the hazards and take precautions to reduce responsibility [Jacob M. Appel, 2019].

6.6 Conclusion

Australia's use of blimps to monitor livestock raises a number of ethical and deontological concerns. Privacy is one of the main ethical issues because using blimps might compromise the privacy of farmers and surrounding properties. Animal welfare is a related moral concern because using blimps might put animals through unnecessarily stressful or upsetting situations. The technology's capabilities must be openly disclosed by sales and marketing experts, and engineers must create and use the technology in a way that is both morally and productively acceptable. The use of blimps for livestock monitoring may disturb the local flora and result in environmental deterioration, raising questions about environmental ethics. Liability concerns must be taken into account, and any risks or negative consequences must be reduced in a way that is ethical and long-lasting. Therefore, taking into account the effects on farmers, animals, locals, and the environment is necessary for the ethical use of blimp monitoring in the production of livestock.

7. Project Development

7.1 Introduction

This chapter's main topic is the thorough project development process, which includes everything from ideation to packaging. We start by talking about the earliest stages of concept development and ideation. The design process is then explored, covering the structural and schematic designs as well as a comparison of the required materials based on attributes like cost and compatibility. We also offer details about our black and grey box and the power budget. The software components of our project are highlighted in the following sections, along with a description of the related tools. Lastly, we finish off with a thorough explanation of our packaging strategy, taking into account a variety of materials that support the goals of our product.

7.2 Ideation

We were given a list of project proposals in order to choose our topic, and we were asked to pick out our top three. We started by talking about our educational backgrounds and strengths to make sure everyone could contribute. We then evaluated each proposal by considering potential problems and solutions. Through open brainstorming, we were able to generate multiple ideas and gather feedback from everyone involved. We used a scale of 0 (No), 1 (Maybe), or 2 (Yes) to make each team member's vote anonymous in order to ensure a fair voting process, as you can see in figure 31. We selected our top three choices after collecting the votes. We ultimately choose the topic outdoor blimp because not only was it our top 1, but the one we were most excited about.



Figure 31: Voting process

After deciding on our topic, we held a brainstorming session to come up with possible uses for the blimp. We came up with a number of options and spoke about each one's practicality and desirability, as shown in figure 32. Our original plan was to use the blimp as a network enhancer for poorly connected locations like rural areas or emergency circumstances. We soon discovered, though, that this concept might be beyond our technical capacity. As a result, we changed our focus to a more practical concept: using the blimp as a surveillance tool for large livestock farms.

Brainstorm Ideas

- **Rescue blimp:** in any case of emergency, the blimp will be thrown and inflated and will send a rescue signal. This is useful to access terrain that is difficult to approach like in the ocean, in the forest, desert, in the mountains, etc. (The two different target groups are rescue workers or people who are in these areas that are in danger).
- **Telecommunication blimp:** it can be temporarily placed to enhance network in places where there is none. This could be several blimps that form a line for communication.
- **Entertainment blimp:** it can take a picture of people during concerts or sport events and afterwards they can buy them at a booth or find them online. An example is the photo you get after being on a rollercoaster. These blimps can also be used as a steam canon, guitar pick canon, light show, etc.
- **Guiding and information blimp:** While a guide, it will show the way in museums or events. A blimp can be following and amplify the guide's voice, show text, or even just float to help with direction. Other example in which this kind of blimp can be used are evacuation of an area, etc.
- **Vision blimp:** the main purpose of this blimp is recording. Some examples where it can be used are in nature documentaries, regular recordings on a film set or for navigation.
- **Coastline Awareness Blimp:** A line of blimps is placed near the coastline that use visual signals to prevent ships in foggy/rainy conditions to hit the shore. For windy conditions they can be fixed to the coast with a non-conducting rope. With a flare they can make a huge signal for the ships where they need to go.
- **Transportation blimp**
- **Wildfire blimp**
- **Speed camera blimp**

Figure 32: Ideas brainstorm process

7.3 Concept

To help Australian farmers manage and monitor their big livestock farms, we came up with the idea of our monitoring blimp. Which can efficiently and effectively survey large areas of farmland, helping farmers to better manage their livestock. This technology will enable farmers to remotely monitor their sizeable herds of cattle from any location. The entire system will be managed by a mobile app, which will give farmers access to real-time information on the condition, location, and other crucial details of their cattle. This will help farmers to make wise choices regarding the welfare of their animals and guarantee that they are given the care they require.

In conclusion, our blimp-based solution is a game-changer for Australian farmers, giving them a practical and effective way to run their huge animal farms and maintain the health and well-being of their cattle.

7.3.1 Logo

We came up with the term ANIMO to stand for our idea of animal monitoring. We thought it was a catchy name that perfectly captured our concept. To prevent outside influence, each team member independently came up with potential names. We created a list of recommendations and used a voting procedure to choose our top choice, which finally resulted in the choice of ANIMO. Unfortunately, we found that the name had already been registered by another business. But, after doing a thorough investigation and speaking with experts in the sector, we discovered that using the same name as long as the businesses are involved in different industries is acceptable. Our logo you can find in figure 33.



Figure 33: ANIMO logo

7.3.2 Mobile mockups

We have created a smartphone application that lets farmers easily access the cameras on their blimps. They may also use the app to directly control the blimps and get an overview of all the blimps. Figure 34 shows a sample of how the mobile app might look like.

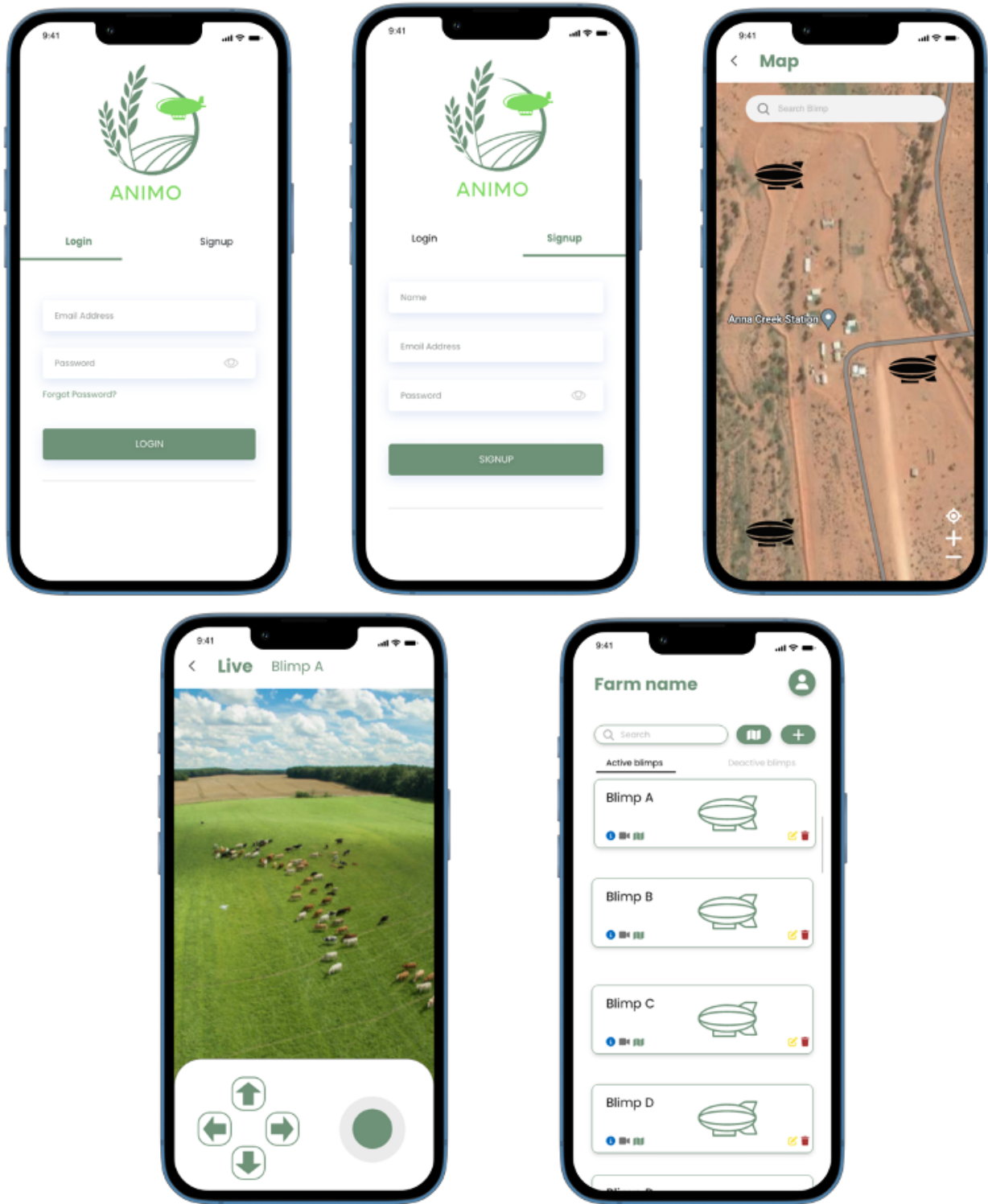

Figure 34: Mobile app mockups

7.4 Design

7.4.1 Structure

7.4.1.1 Structural Draft

The drawing in Figure 35 is made to convey the basic concept for the blimp's structural design. The entire blimp, including the envelope, which has no internal structure, is visible in the upper left. The majority of the electronic components, including the battery and the microcontroller, are mounted inside the gondola (top right), which is visible in the sectional image at the bottom. The gondola's sides are angled to give the camera on the outside an excellent area view. The propeller, the motor that powers it, and the servo motor that steers the angle of the propeller-motor make up the propulsion system. The landing gear is made up of two parts and is built in such a way that the propellers do not strike the ground when the blimp is landing.

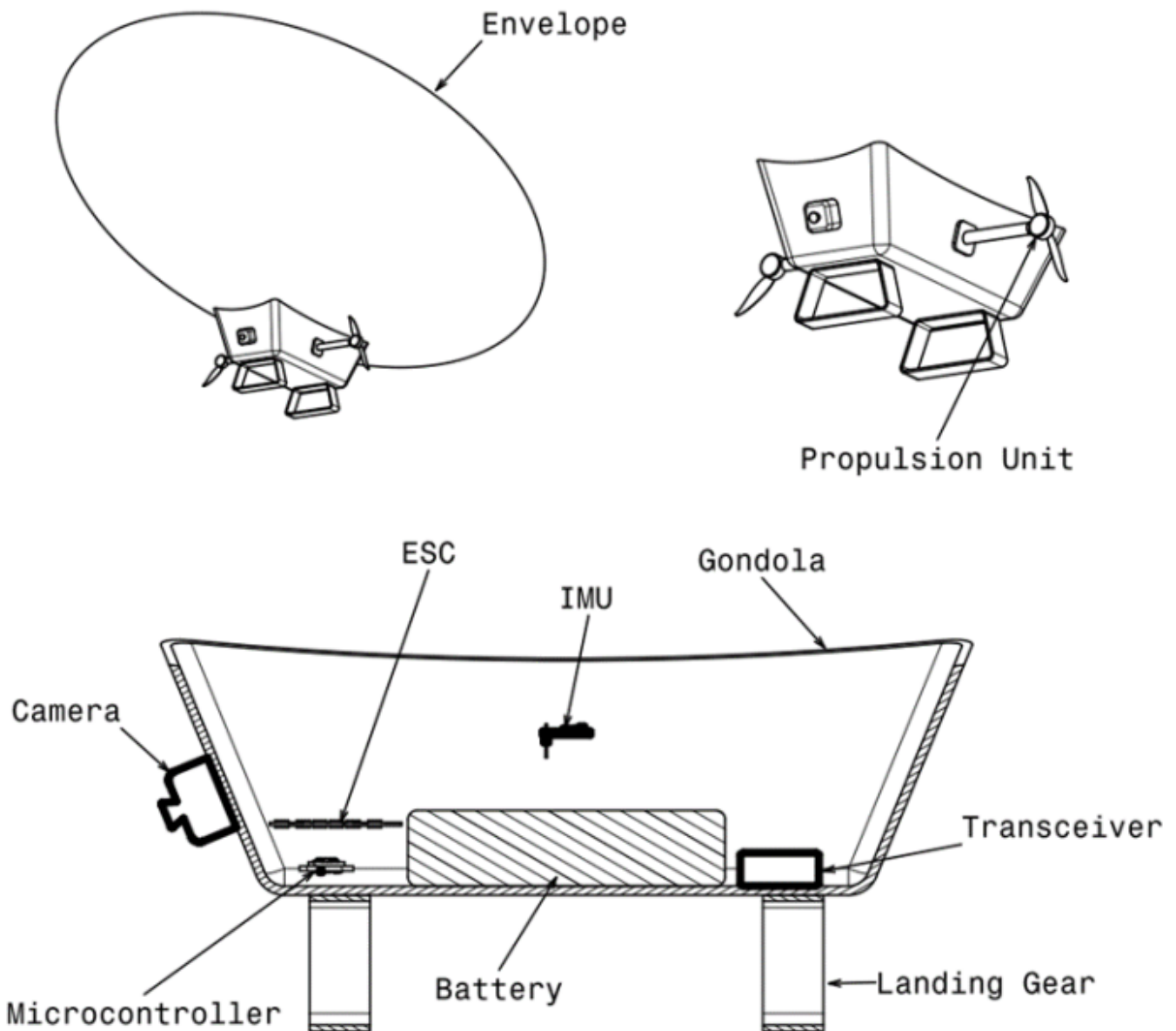

Figure 35: First structural draft

7.4.1.2 Detailed Structural Draft

The drawing shown in Figure 36 has a higher level of detail than Figure 35. Changes have also been made. For example, the camera has been moved inside the gondola. The arms on which the drive

units are mounted have been linked by a splined coupling so that they can be angled synchronously via a gear wheel. Furthermore, the floor was designed as a removable single part, so that access to the interior is possible.

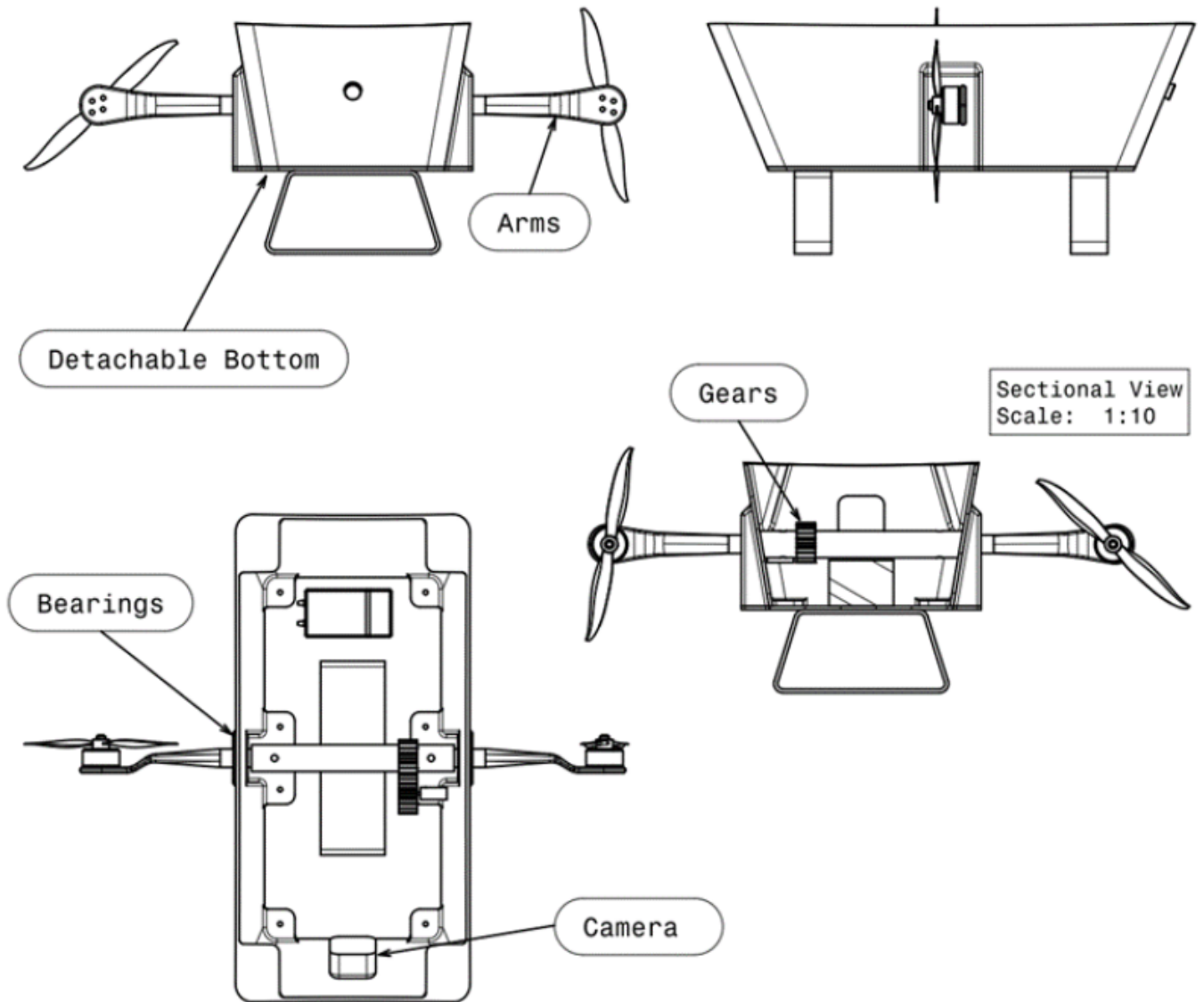

Figure 36: Detailed structural draft

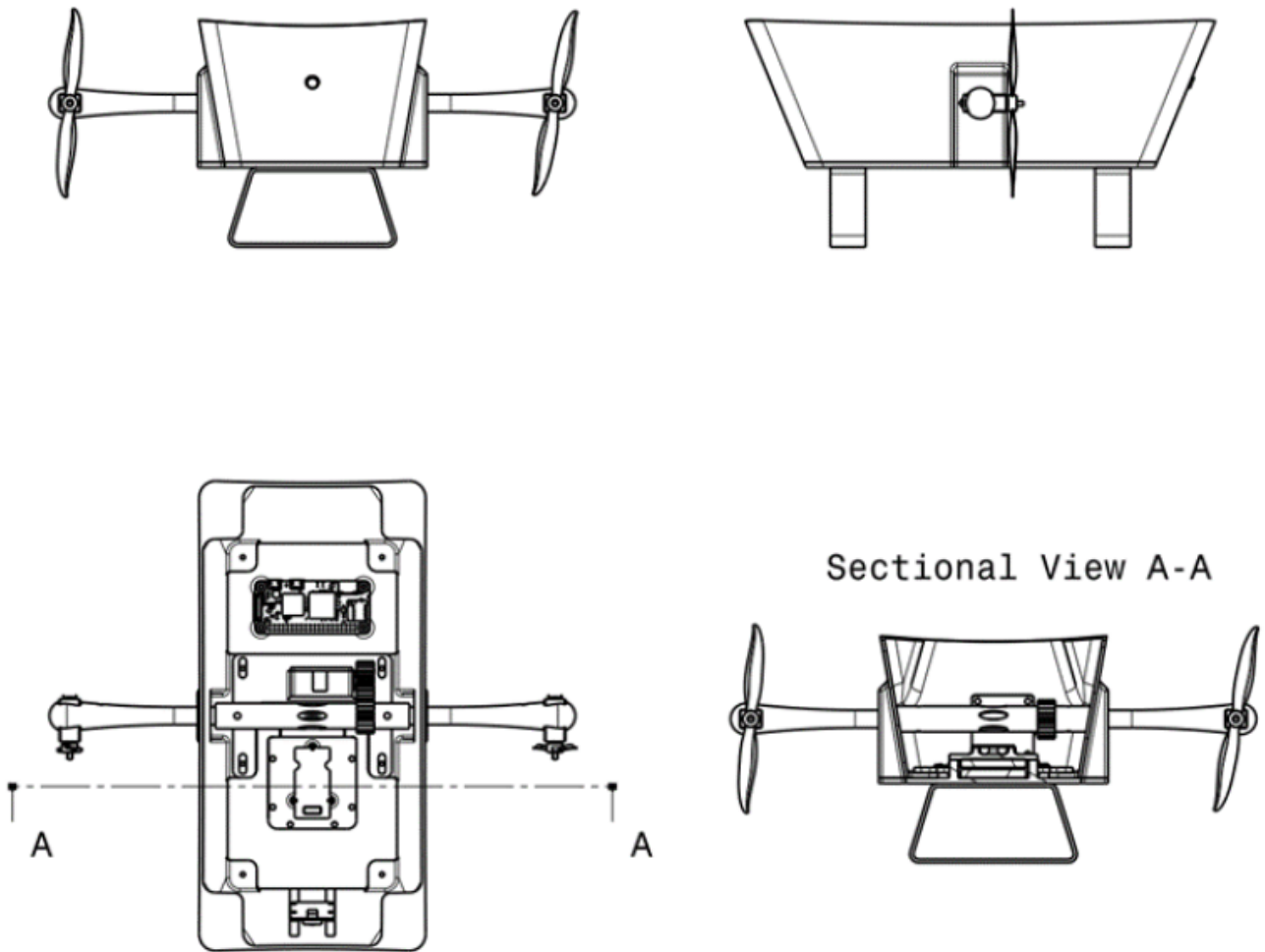

Figure 37: Detailed structural draft of the improved blimp

7.4.1.3 Lift Capacity

Lift Capacity Diagram

The size of the envelope is highly dependent on the mass to be transported. The filling volume must be adjusted to the sum of the masses of the components so that the equilibrium of forces is fulfilled and the blimp can remain at a certain height in the static state. It is therefore advisable to proceed in the order of first defining the components and then determining the size of the blimp. The following diagram shows the rapid increase in size at low masses, which occurs due to the exponential nature of the loading capacity as a function of the length of the ellipsoidal envelope. Also, the gas chosen for the blimp, helium, and air are assumed to be ideal gases, so the ideal gas equation can be applied.

$$p \cdot \rho = R_s \cdot T$$

In this equation, the relationships hold $(p: \text{pressure})$, $(\rho: \text{density})$, $(R_s: \text{specific gas constant})$ and $(T: \text{temperature})$.

Furthermore, the following values were assumed for the calculation.

$$p_{\text{Air}} = 101325 \text{ Pa}$$

$$[R_{S, \text{Air}}=287 \frac{\text{J}}{\text{kg}\cdot\text{K}}]$$

$$[R_{S, \text{He}}=2077 \frac{\text{J}}{\text{kg}\cdot\text{K}}]$$

$$[T=20 \text{ }^\circ\text{C}]$$

$$[\rho_{\text{Air}}=1.204 \frac{\text{kg}}{\text{m}^3}]$$

$$[\rho_{\text{He}}=0.249 \frac{\text{kg}}{\text{m}^3}]$$

The envelope is a rotational ellipsoid. That means it's the Volume generated by an ellipse rotated around it's semi major axis. The semi major axis (a) is one of two axis that define an ellipse, with the other being the semi minor axis (b). The geometrical meaning of those two axis is conveyed in Figure 38.

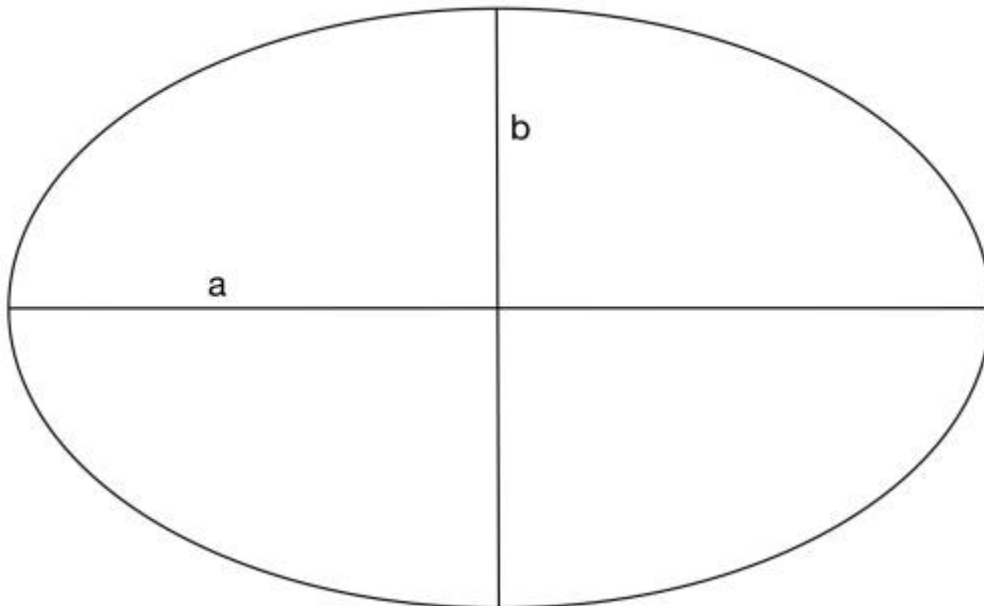

Figure 38: The semi major (a) and the semi minor axis (b) of an ellipse

Because the volume of the envelope and therefore the lift capacity of the blimp depend on the ratio between these two, this ratio was set to a certain value.

$$[\frac{\text{semi major axis}}{\text{semi minor axis}}=2.4]$$

Those assumptions result in the diagram of the lift capacity shown in Figure 39.

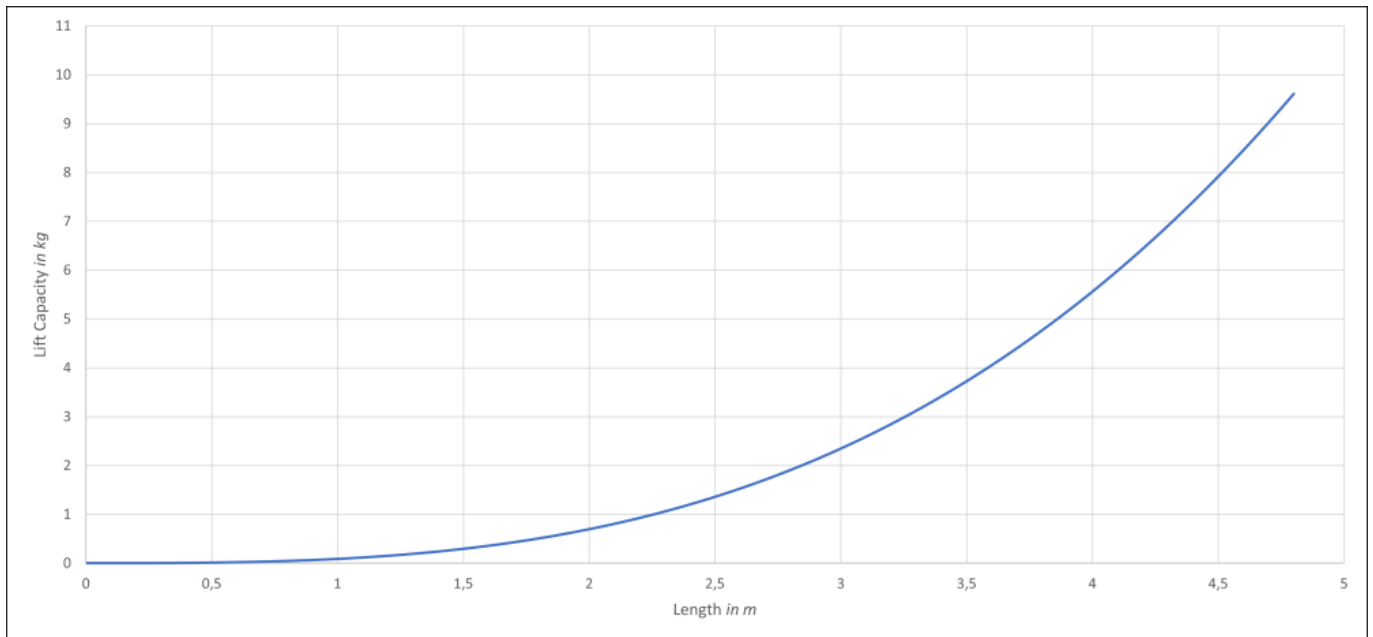

Figure 39: Diagram of the lift capacity

7.4.1.4 Materials

Envelope Material

To determine the materials used for the envelope of the blimp, different properties, such as strength, weight, gas-tightness, weather and UV stability, have to be evaluated [Casey Stockbridge, Alessandro Ceruti, Pier Marzocca, 2012]. Since there is no material available, that has favourable values for all those properties, a laminate structure of 3 separate materials is chosen. This approach is influenced by the approach of C. Stockbridge, et al. [E. Callut P. Hendrick M. Duponcheel N. Caeymax J. Buret S. Gohy L. Fitschy O. Banse M. Bruyneel, 2019]. The most inner layer is the so called Load Bearing and it's job is to bear most of the load that is applied to the laminate structure. The middle layer is called the Gas Retention Layer. This layer hinders the gas from escaping the envelope. To shield the two inner layers from the environment the most outer layer, called Weathering Protection Layer, has to have a high weatherability and high life expectancy without being too heavy. The following tables provide an overview about various materials, that may be used for the said laminate structure [E. Callut P. Hendrick M. Duponcheel N. Caeymax J. Buret S. Gohy L. Fitschy O. Banse M. Bruyneel, 2019].

Table 42 lists various materials that can be used for the Load Bearing Layer.

Table 42: Materials for the Load Bearing Layer

Material	Polyester	Polyamides	Aramid	Polyimides
Examples	<i>Vectran, Dacron</i>	<i>Nylon</i>	<i>Kevlar</i>	<i>Nomex</i>
Advantages	<ul style="list-style-type: none"> - High Strength - Good dimensional stability - Minimum elongation - Low crimp interchange - High tear resistance - Good Provenance 	<ul style="list-style-type: none"> - Very low specific gravity (1.14) 	<ul style="list-style-type: none"> - Greater fiber modulus - Very high tensile strength 	<ul style="list-style-type: none"> - Similar to polyesters in most respects - Extremely good fire retardation properties (Although not very relevant for Helium based airships)
Limitations	<ul style="list-style-type: none"> - Relatively higher specific gravity than nylon (1.39) 	<ul style="list-style-type: none"> - Poor dimensional stability - Longer life 	<ul style="list-style-type: none"> - Susceptible to Actinic degradation - Not able to disperse stress concentrations formed during manufacturing large envelopes - Higher cost than polyester 	<ul style="list-style-type: none"> - Higher cost

Table 43 and 44 list various materials that can be used for the Gas Retention Layer.

Table 43: Materials for the Gas Retention Layer (1)

Material	Tensile Strength	Ultimate Elongation	Gas Permeability	Adhesion To Fabric
Polyurethane	4,000 - 10,000	400 - 600	Low	Excellent
Polyvinyl Fluoride	8,000 - 16,000	90 - 250	Low	Poor
Polyester	25,000 - 45,000	40 - 120	Low	Fair
Nylon	10,000 - 17,000	300 - 500	Very Low	Fair
Polyvinylidene Chloride Copolymer	7,000 - 16,000	30 - 60	Very Low	Fair
Polytetrafluoroethylene	3,000	300	Fair	Poor
Low Density Polyethylene	1,000 - 2,300	90 - 800	Fair	Poor
Polyvinyl Chloride	1,000 - 3,000	200 - 400	Fair - Low	Excellent

Table 44: Materials for the Gas Retention Layer (2) [43](#)

Material	Heat Sealable	Weatherability	Flex Fatigue Resistance	Dimensional Stability
Polyurethane	Yes	Good	Good	Poor
Polyvinyl Fluoride	Yes	Excellent	Excellent	Good
Polyester	No	Fair	Fair	Excellent
Nylon	-	Poor	Excellent	Excellent
Polyvinylidene Chloride Copolymer	Yes	Poor	Fair	Good
Polytetrafluoroethylene	Yes	Excellent	Good	Good
Low Density Polyethylene	Yes	Good if pigmented	Excellent	Poor
Polyvinyl Chloride	Yes	Good	Good	Poor

Table 45 lists various materials that can be used for the Weathering Protection Layer.

Table 45: Materials for the Weathering Protection Layer

Material	Neoprene	Polyurethane	Polyvinyl Fluoride (PVF)
Advantages	Modest weatherability, needs painting every 3 years	Very low Helium permeability; Very good handling properties; Crease resistance and Good weatherability	Excellent resistance to weathering, staining, chemical attack; Exhibits slow burning and low gas permeability
Limitations	Specific gravity 50% higher than PU or PVF; Poor adhesion (external adhesive must be used)	Poor thermal capability; attacked by most solvents; Flammable	High Cost
Helium permeability	Average	Very Low	Very Low
Weatherability	Modest	Good	Excellent
Life and maintenance	Repainting after 3 years	5 Years with modest maintenance	15 to 20 years with no maintenance
Specific gravity	High (50% more than PU and PVF)	Average	Average
Handling	Adhesive required	Very easy (adhesive or heat bonding)	Easy

Based on those evaluations the composition of materials shown in Table 46 will be used for the envelope of the blimp. In the following the reasons for the choice of materials will be explained. Comparisons that will be made are relative to the other listed materials. The layer that bears the main part of the load will be made out of polyester woven fabric (Vectran), because the high strength, the high tear resistance and the low elongation, which is advantageous for the stability of the blimp. The only limitation is the relatively higher specific gravity compared to nylon. As the Gas Retention Layer

a Polyester based film was chosen mainly due to its low gas permeability. Other advantages of this material are the high dimensional stability and the high tensile strength. Even though there are materials with a lower gas permeability they can't be used for the gas retention layer because of their poor weatherability. The weathering protection layer will be made out of Tedlar (Polyvinyl Fluoride). It has an excellent weatherability and a very high life expectancy of 15 to 20 years with no maintenance needed.

Layer of Laminate	Material Chosen	Type of Material
Load Bearing Layer	Vectran	Polyester Woven Fabric
Gas Retention Layer	Mylar	Polyester Based Film
Weathering Protection Layer	Tedlar	Polyvinyl Fluoride

Table 46: Composition of the laminate structure of the envelope

Mechanical Components

ASA (Acrylonitrile Styrene Acrylate), ABS (Acrylonitrile Butadiene Styrene), PLA (Polylactic Acid), and PP (Polypropylene) are all types of plastics that have various properties that make them suitable for different applications. The chart in Figure 40 is there to convey, how different plastics compare to one another in terms of specific strength and price.

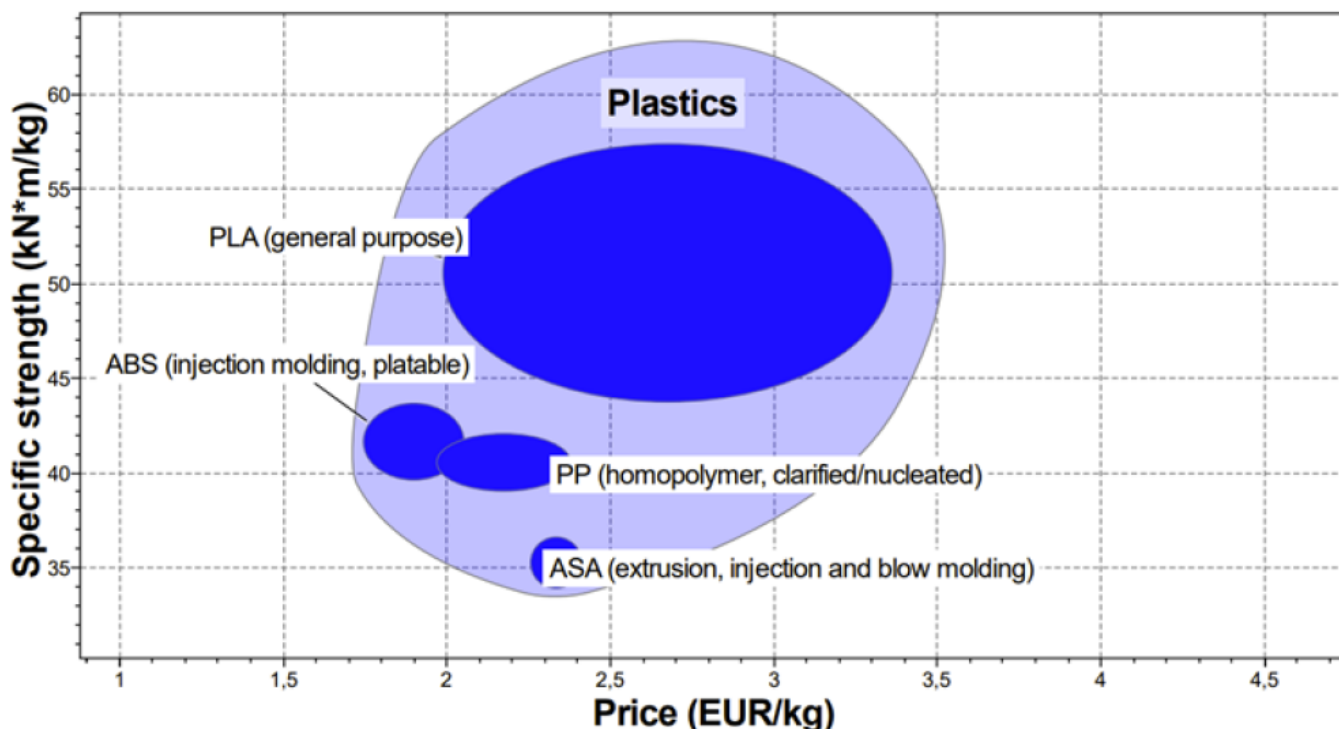

Figure 40: Comparison chart of the specific strength and price of different plastics

Table 47: Comparison of different aspects of certain plastics

Nb.	Material	Density $[\text{g/cm}^3]$	Young's Modulus $[\text{MPa}]$	Yield Strength $[\text{MPa}]$	Tensile Strength $[\text{MPa}]$	Elongation at Yield	Elongation at Break	Melting Temperature $[\text{°C}]$	Vicat Softening Point $[\text{°C}]$
1.	PLA	1.24 - 1.27	3300 - 3600	50 - 55	55 - 72	2 - 3.5 %	2.5 - 6 %	145 - 175	51 - 56
2.	ABS	1.04 - 1.07	2210 - 2620	42 - 46	42 - 46	1.7 - 6 %	15.3 - 20.9 %	210 - 250	91 - 111
3.	ASA	1.05 - 1.06	1510 - 2340	35.9 - 38.6	27.6 - 51.7	5 %	25 - 40 %	220 - 260	91 - 111
4.	PP	0.9 - 0.91	1600 - 1780	35.4 - 38	36.2 - 49	7.31 - 9.03 %	43 - 73.2 %	160 - 169	144 - 165

In the following, additional factors like sustainability and outdoor usage are taken into consideration.

Outdoor usage

- ASA (Acrylonitrile Styrene Acrylate) is a weather-resistant thermoplastic that is often used for outdoor applications. It has excellent UV resistance, good dimensional stability, and high impact strength, making it suitable for use in automotive parts, outdoor furniture, and other outdoor applications.
- ABS (Acrylonitrile Butadiene Styrene) is another thermoplastic that is used for outdoor applications. However, it is not as weather-resistant as ASA, and its colour can fade when exposed to sunlight for long periods. It is commonly used in automotive parts, toys, and electronic housings.
- PLA (Polylactic Acid) is a biodegradable thermoplastic that is not suitable for long-term outdoor use as it can degrade when exposed to UV light and moisture. However, it is often used for short-term outdoor applications such as planters and packaging.
- PP (Polypropylene) is also not recommended for long-term outdoor use as it can become brittle and degrade over time. However, it is commonly used for outdoor furniture, automotive parts, and packaging due to its good resistance to moisture and chemicals.

Price

- ASA is more expensive than ABS and PP due to its superior weather resistance and impact strength.
- ABS is relatively inexpensive compared to ASA, PLA, and PP.
- PLA is generally more expensive than ABS and PP due to its biodegradability and sustainability features, but also has the biggest range in terms of price.
- PP is more expensive than ABS, but cheaper than ASA due to its widespread availability and low production costs.

Specific Strength

- ABS has a relatively good specific strength of 39.2 kN*m/kg - 43.5 kN*m/kg and is commonly used in applications where impact resistance is important.
- PP has a specific strength of 39 kN*m/kg - 42 kN*m/kg, which is slightly below the specific strength of ABS, and is commonly used in applications that require resistance to chemicals and moisture.
- PLA generally has the highest specific strength of the compared plastics and it is biodegradable and eco-friendly.
- ASA has the lowest specific strength of the compared plastics, but has the best weather resistance and UV stability.

Sustainability

- ASA and ABS are not biodegradable and are made from petrochemicals, making them non-sustainable.
- PLA is biodegradable and made from renewable resources such as cornstarch and sugarcane,

making it a more sustainable option.

- PP is not biodegradable, but it is recyclable, making it a more sustainable option than ASA and ABS.

In summary, ASA and ABS are suitable for outdoor use and have good specific strength, but are not sustainable. PLA is a biodegradable option that is suitable for short-term outdoor use and has lower specific strength. PP is a cost-effective option that has good specific strength and is recyclable, making it a more sustainable choice.

Due to the application of the ANIMO blimp, which is outdoors, it is exposed to a high dose of UV radiation. Since the sustainable plastics, that in general could be used for the mechanical components, are not resistant to UV radiation, they can't be the material of choice for the components that will be exposed to the sunlight. Instead of this either ABS or ASA can be used for the "outside" components of the ANIMO blimp. Those components are the Gondola, the detachable bottom, the arms and the landing gear. Because it is not expected, that the blimp will face harsh impacts, the specific strength of ABS is not needed. Because of this, and due to the very good weather and UV resistance, ASA is chosen as the material for the "outside" components.

The "inside" components won't face any UV radiation and are also not exposed to the weather. This creates a shift of requirements compared to the other components. The material has to be sustainable, relatively light-weight yet suitable for mechanical load and relatively cheap. PP meets those requirements to a high extent. Especially the sustainability and the price per kg of 1.95 € - 2.38 € make this plastic a nice fit for the "inside" components.

7.4.1.5 Stress Analysis

In order to evaluate the geometric construction and the selection of the material with regard to the loads, two different load cases are created that are intended to reflect real situations. The two load cases are:

- 1. Loading of the front right corner of the gondola with a force of approx. 235 N
- 2. Loading of the toothed coupling with a force of approx. 22 N

The force of the second load case (figure 47) results from the maximum torque of the servomotor of approx. 0,22 Nm and the pitch circle diameter of the gear wheel attached to it of 10 mm. Figure 41 shows the direction of the force vector from the 1st load case. It acts perpendicular to the axis of the radius of the corner and at a 45° angle to the adjacent side walls of the gondola. This direction of loading is particularly unfavourable for the structure.

It is pointed out that individual components of the original structure are neglected in the analysis. On the one hand, the electronic components, since they were deliberately integrated into the design in such a way that they experience little to no stress when deformed, and also because no information is available about their mechanical properties. On the other hand, the envelope is not taken into account because, as with the electronic components, there is no information on the mechanical properties. Furthermore, isotropic material behaviour was assumed. However, whether a material is isotropic is influenced, among other things, by the manufacturing process. Since no exact information is available in this regard either, this influence is neglected.

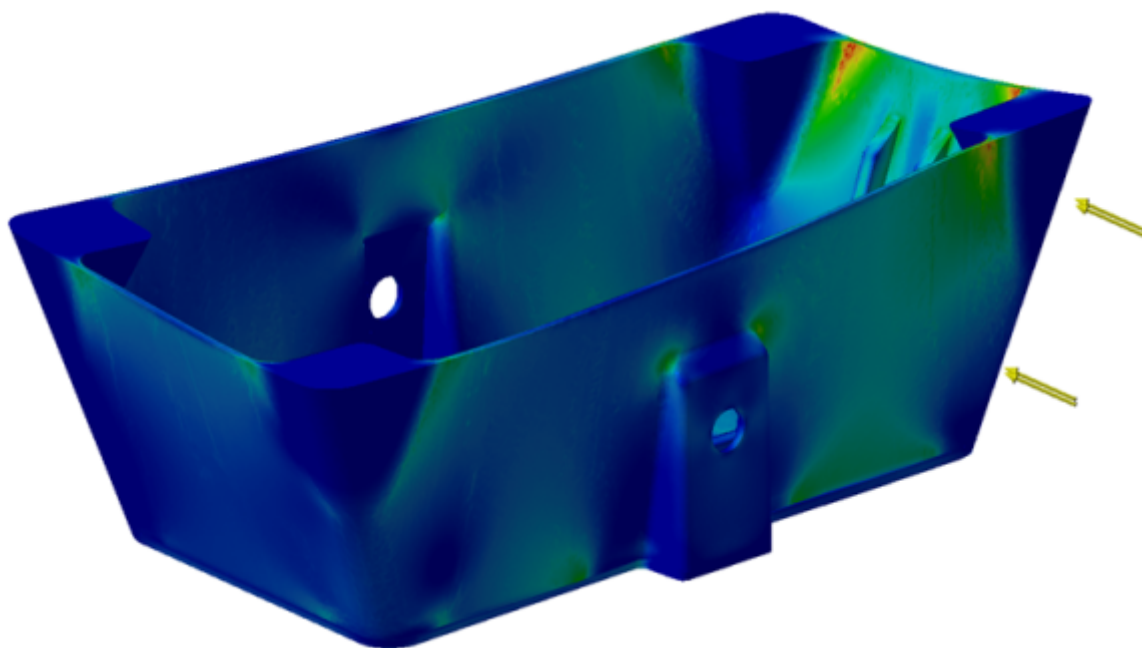

von Mises Stress (node values)

N_m2

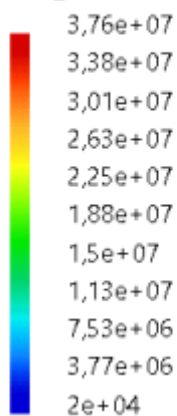

Figure 41: Isometric view of the stress analysis scaled to the maximum stress with the applied load

In Figure 42 the loaded corner of the nacelle is shown in the foreground. Stress concentrations can be seen at the upper edge, which can be easily explained by the notches there. The maximum stresses are located at these points. This means that if the load increases at this point, there is a high probability that the material will fail. In addition, elastic deformations can be seen with a scaling of 1:1.

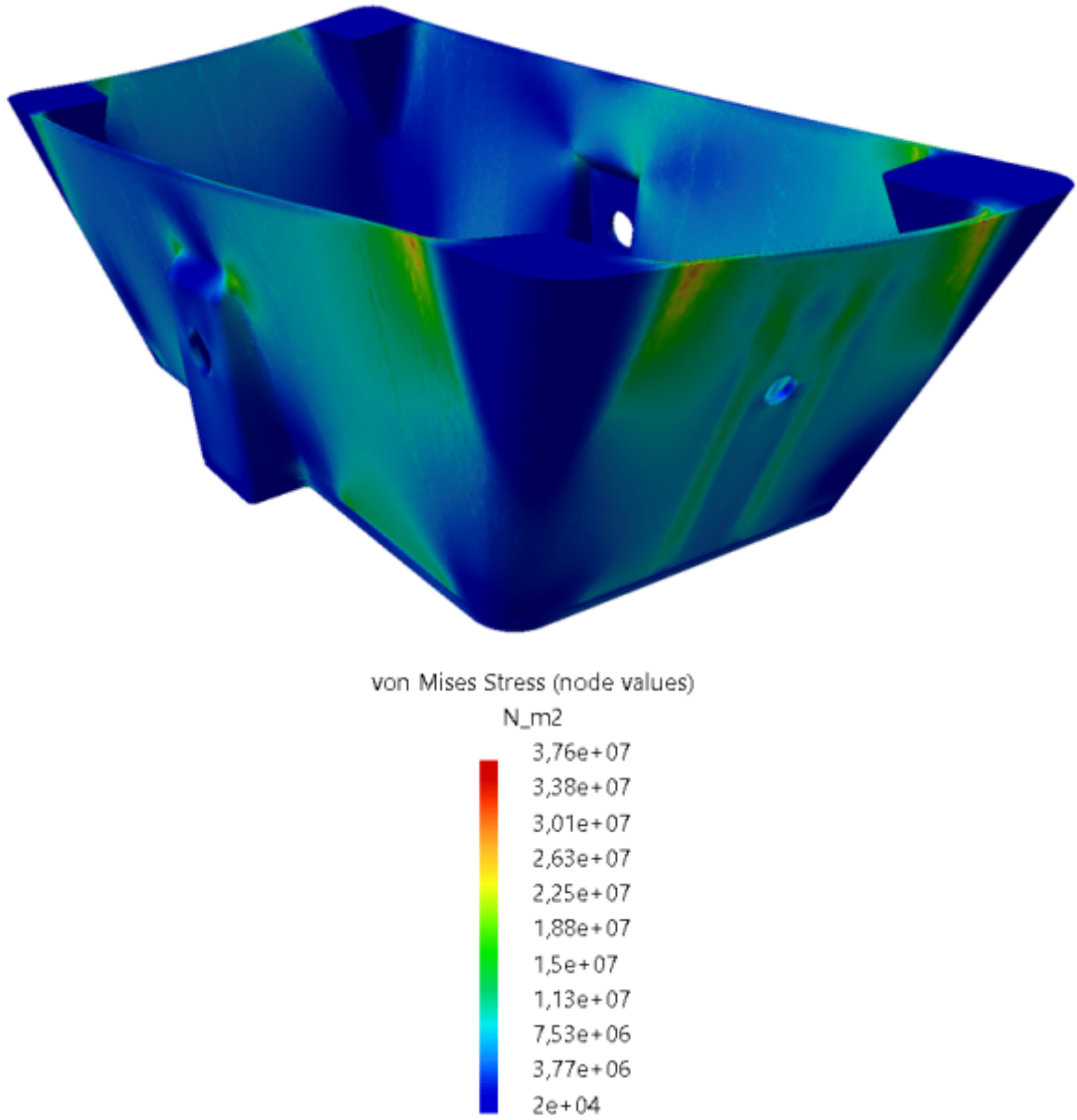
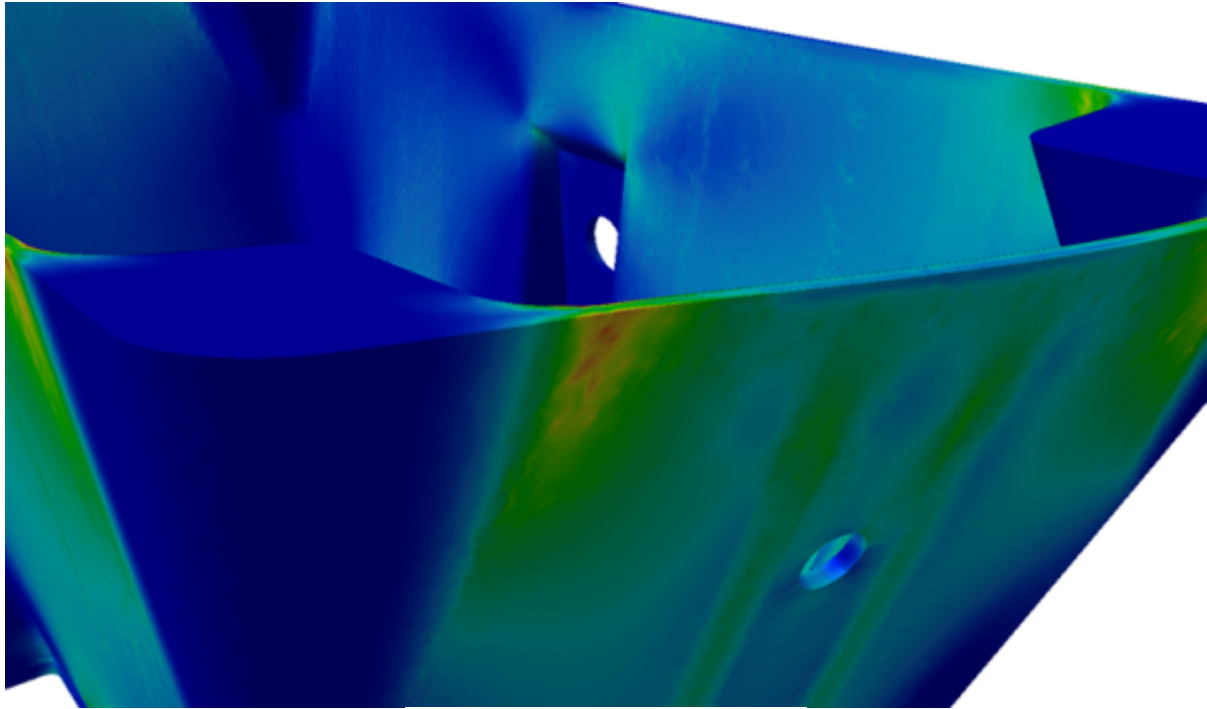

Figure 42: Isometric view of the stress analysis scaled to the maximum stress

The stress pattern shown in Figure 42 is enlarged in Figure 43. This makes the potential vulnerability easier to identify.



von Mises Stress (node values)

N_m2

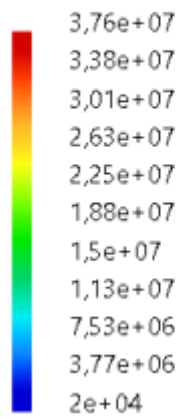
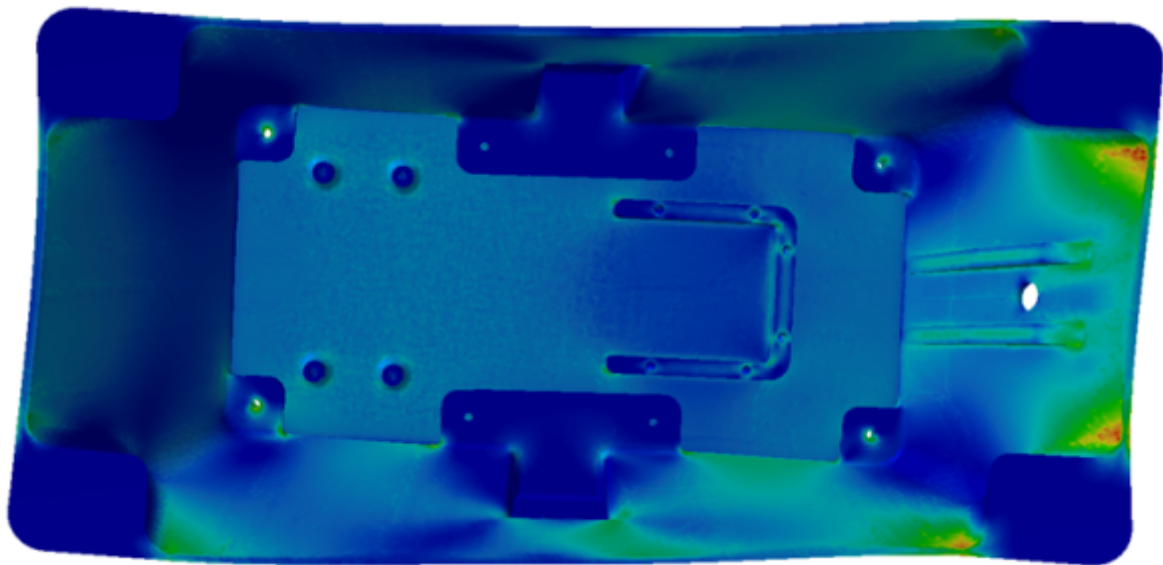

Figure 43: Close up of the point of maximum stress scaled to the maximum stress

Figure 44 is mainly used to illustrate the deformation that occurs. The gondola is bent in an S-shape, which indicates the presence of shear stresses and bending moments. It should also be pointed out again in this representation that this is the actual deformation.



von Mises Stress (node values)

N_m2

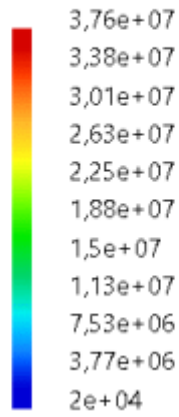
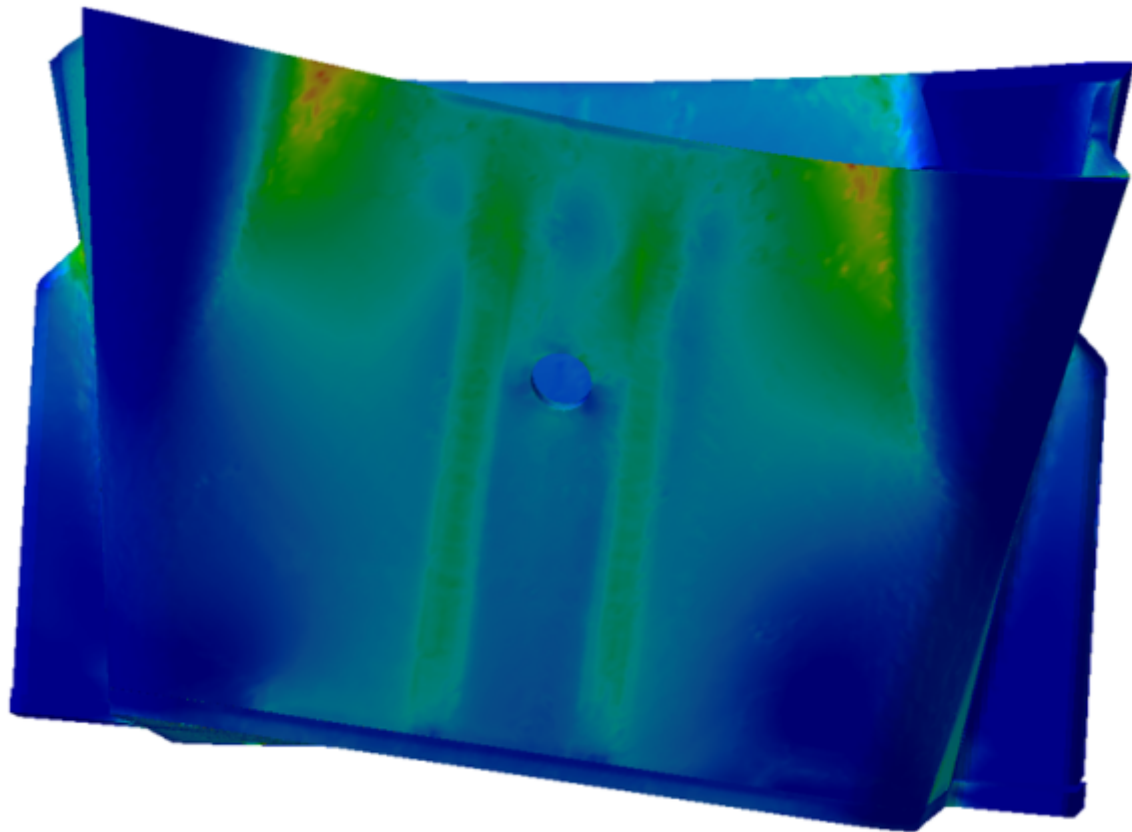

Figure 44: Top view of the stress analysis scaled to the maximum stress

Similar to Figure 44, Figure 45 is used to illustrate the deformation of the structure.



von Mises Stress (node values)

N_m2

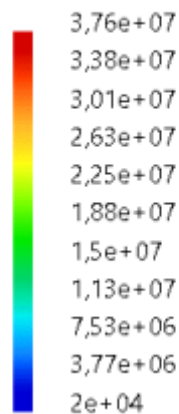
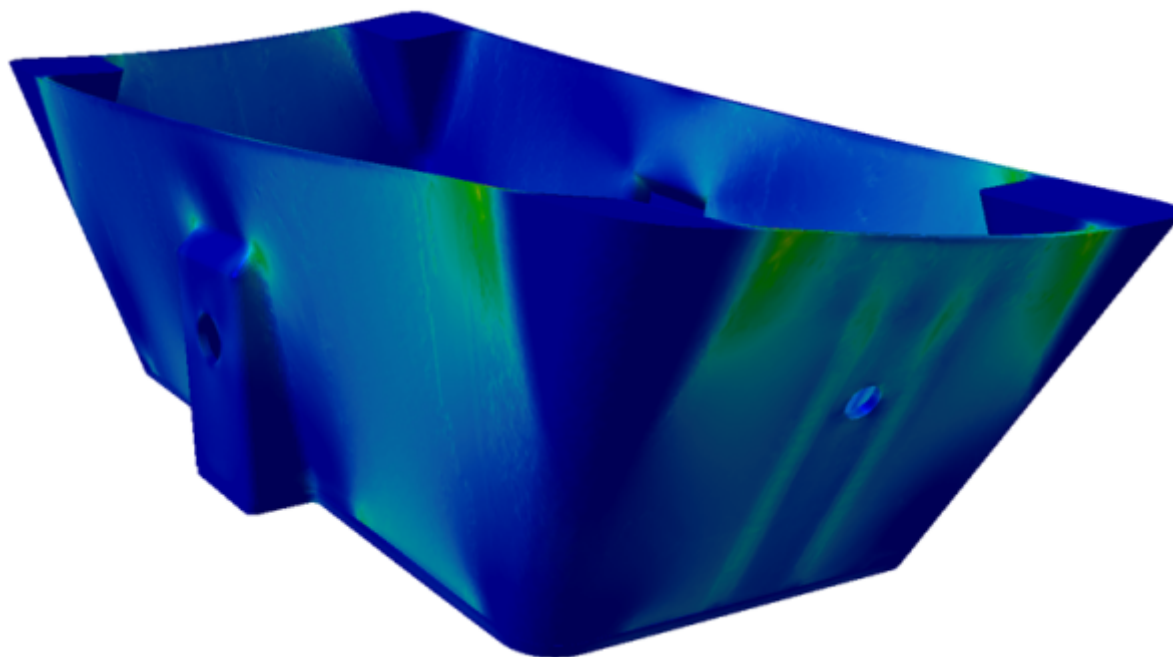

Figure 45: Front view of the stress analysis including the deformation scaled to the maximum stress

In contrast to the previous figures, the stress pattern in Figure 46 is not scaled to the maximum stress that actually occurs, but to the maximum allowable stress, the so-called yield strength. Both the colour image and the colour scale show that the blimp is not at risk of material failure under the conditions described in the 1st load case.



von Mises Stress (node values)

Max: 3,75644e+07 N_m2

Min: 19952,1 N_m2

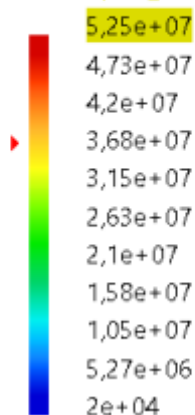

Figure 46: Isometric view of the stress analysis scaled to the yield strength

The results of the simulation of the second load case are now presented and evaluated. As explained at the beginning, the toothed coupling, which is responsible for realizing the synchronous movement of both arms, is loaded on one side on one tooth flank with a force that reflects a load at maximum torque of the servo motor. This case can occur when the rotational movement of the arms and the clutch is blocked. The resulting force vector of the surface load is oriented in such a way that it runs tangentially along the root circle of the integrated gear wheel. Due to the involute toothing of the gear wheel, this is a good approximation of reality. Figure 47 shows the stress pattern of the 2nd load case with scaling to the maximum stress that actually occurs. A particularly important finding from this figure is that the elliptical cut-outs in the middle of the coupling, which are intended for the motor cables, hardly cause any stress.

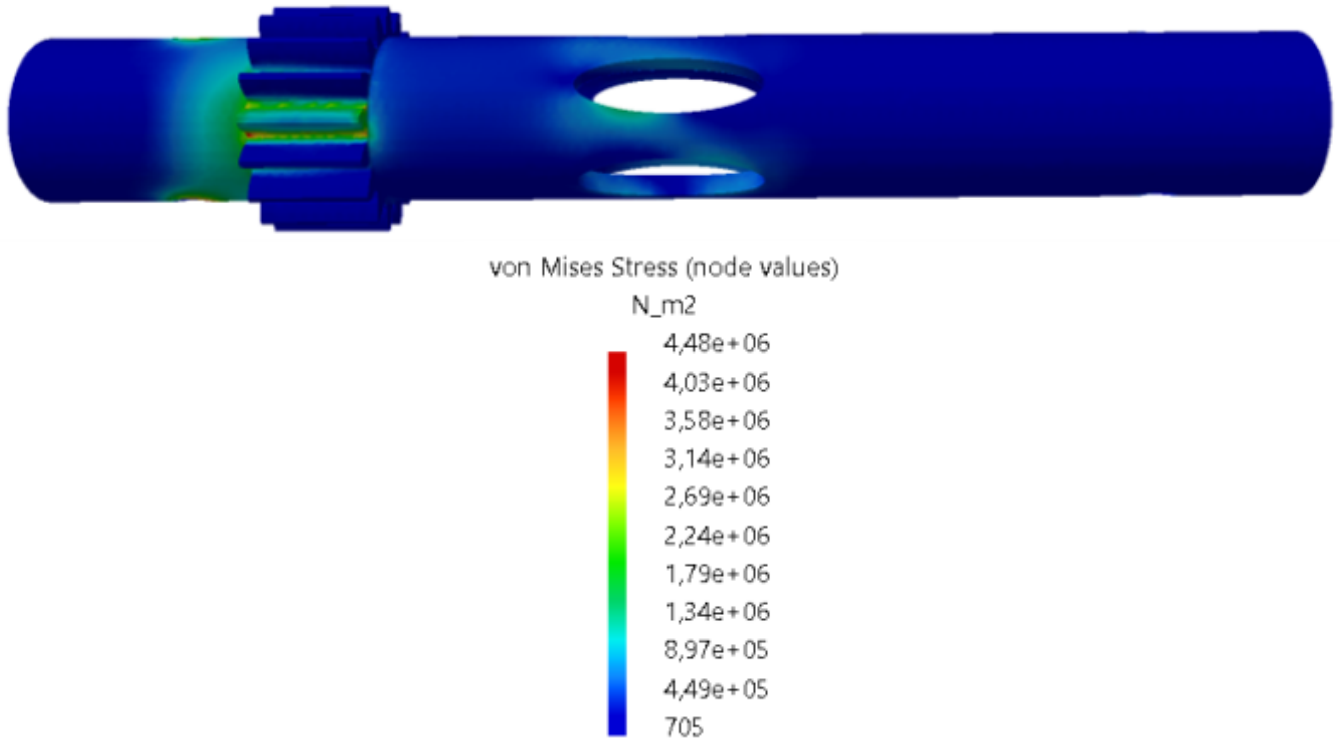
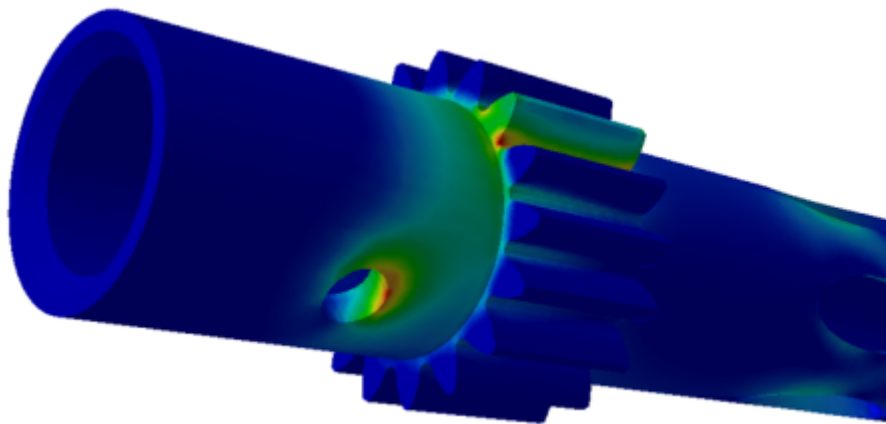

Figure 47: Front view of the stress analysis scaled to the maximum stress

Figure 48 shows the location of the maximum stress. The fact that this is located at the loaded tooth base is not surprising. The tooth root is not only the point of the tooth that is exposed to the highest bending moment, but also a notch point.



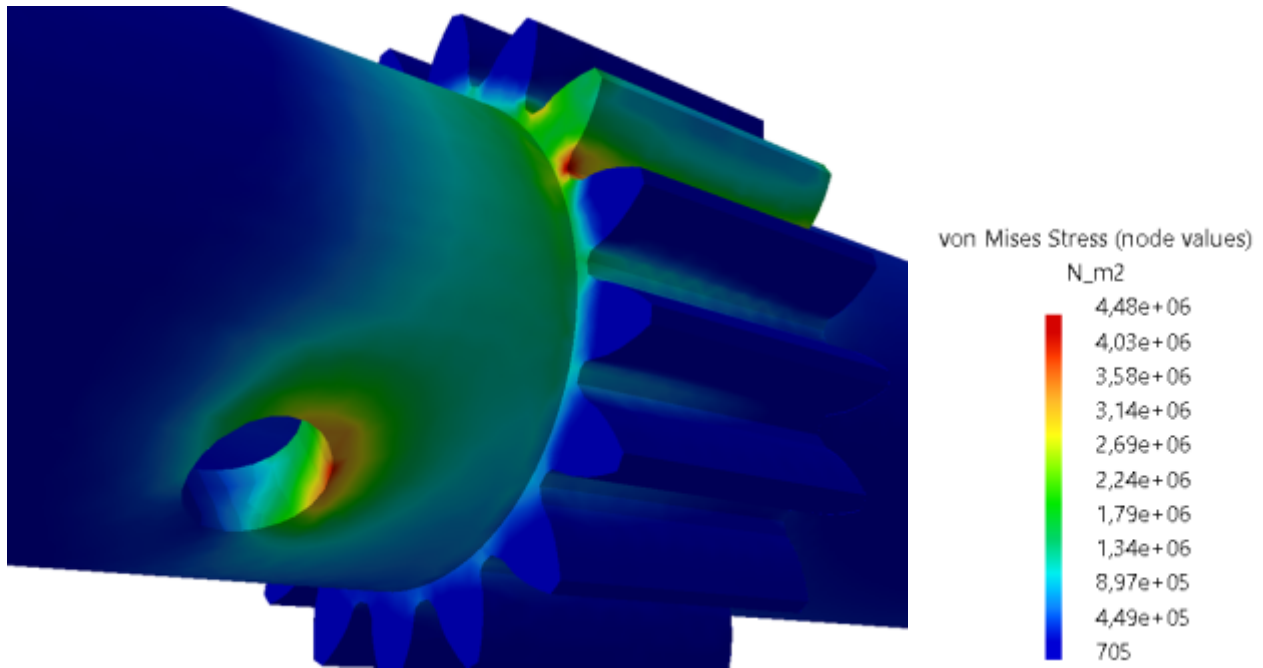

Figure 48: Close ups of the stress analysis scaled to the maximum stress

Contrary to what one might assume based on the previous images, the component is not at risk of material failure. Figure 49 shows the stress pattern of the entire component scaled to yield strength. With a stress reserve of over 90 %, oversizing can be assumed.

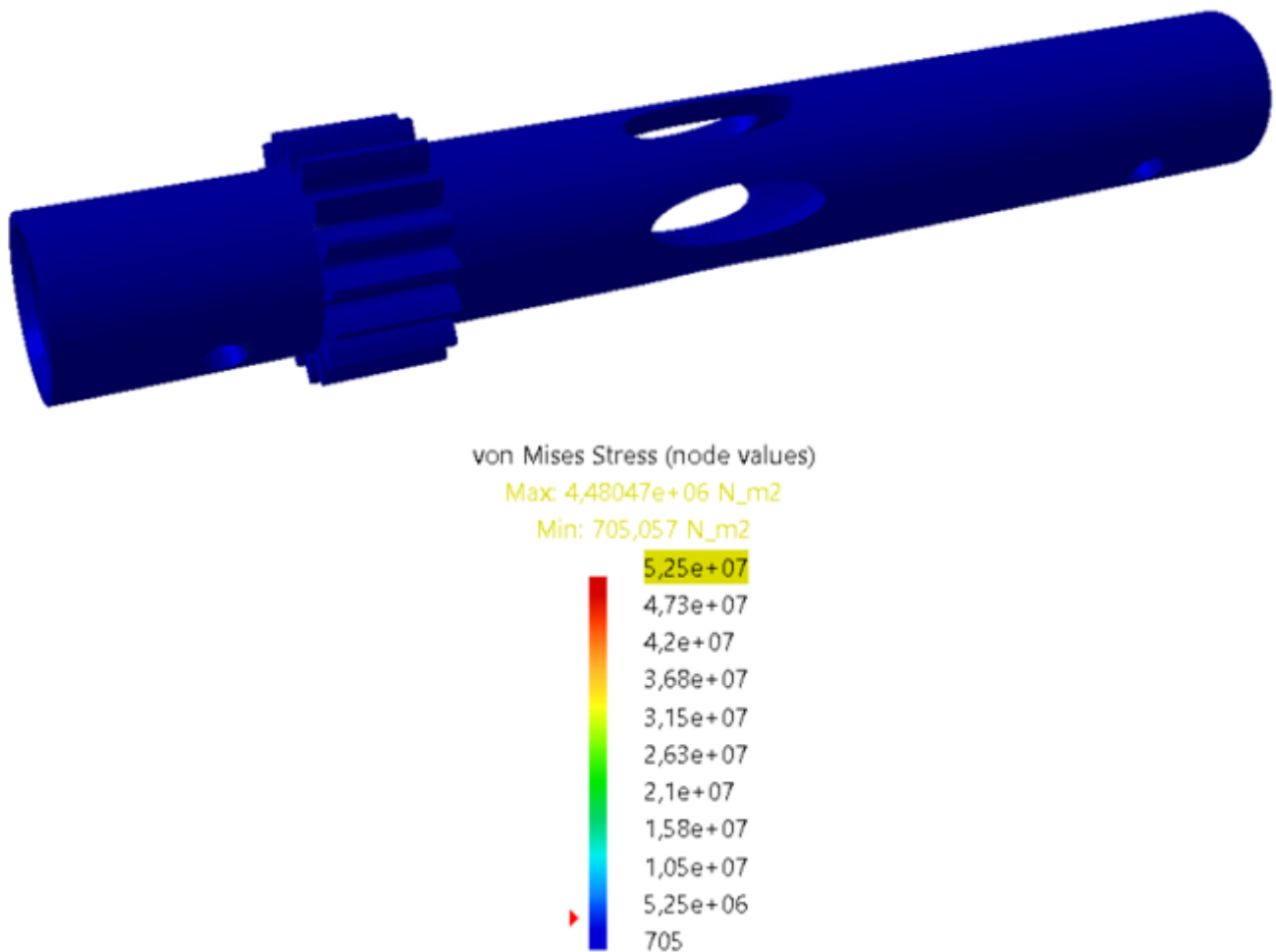

Figure 49: Front view of the stress analysis scaled to the maximum stress

7.4.2 Smart System

Hardware

Blackbox Diagram

The blackbox diagram shown in Figure 50 is intended to provide a general overview of how the product works and how it interacts with its environment. The labelled rectangles represent individual components or groups of components of the product system. Surrounded by the dashed rectangle is the blimp itself. Connections between the labelled rectangles can occur in three ways: solid line arrow, dashed line arrow, and dotted line arrow. The meaning of the different line types is shown in the legend at the top left.

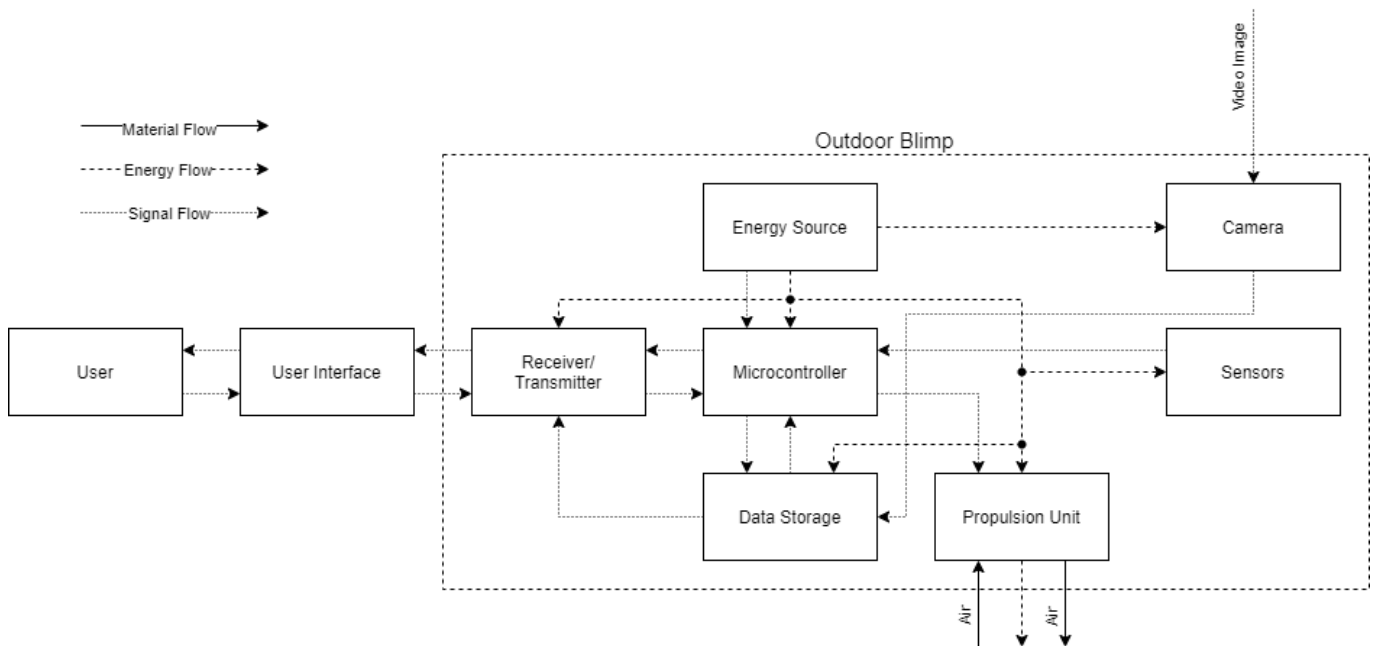

Figure 50: Blackbox diagram of the outdoor blimp

The user operates the blimp via the user interface, which also transmits information to it. The user interface converts the user's commands into signals that are received by the transceiver, which is a combination of a receiver and a transmitter. In the further process, the transceiver transmits the signals to the microcontroller. The microcontroller processes them and compares them with the signals from the sensors - this allows the target and actual status to be determined. Control commands for the drive unit are derived from the comparison and transmitted to the same. By releasing energy to the environment, the drive unit generates an air flow that provides the appropriate propulsion. Parallel to this control process, the camera records a video image of the surroundings and sends it to the data memory, which in turn forwards it to the transceiver. This data transmission was chosen in order to be able to decide, depending on the presence of a received signal, whether to send the video image without saving it or to save the video image without sending it. All components are supplied with energy via an energy source.

Evaluation of the Electrical Components

In order to create an evaluation basis for the comparison of the various alternatives of the respective

electronic components, an approach was chosen in which technical merits are the result. To do this, certain characteristics of a component are evaluated and then multiplied by a weighting, which creates a partial technical merit. The evaluation takes place by means of the ratio of the respective value of a characteristic to the maximum value of the same.

If a high value of a characteristic is advantageous, the evaluation is carried out as follows.

$$\text{Partial Technical Merit}_{ik} = \frac{\text{value}_{ik}}{\text{value}_{k, \max}} * \text{weighting}_{k}$$

On the other hand, there is the evaluation when a low value of a characteristic is advantageous.

$$\text{Partial Technical Merit}_{ik} = 1 - \frac{\text{value}_{ik}}{\text{value}_{k, \max}} * \text{weighting}_{k}$$

The index (i) stands for the rows and the index (k) for the columns of the table where the characteristics are listed.

To calculate the total technical merit, or just technical merit, all the partial technical merits of one alternative are added.

$$\text{Technical Merit}_{i} = \sum_{k} \text{Partial Technical Merit}_{ik}$$

The weightings were chosen according to the influence on the overall product and are always adding up to 100 %, so that the best possible product results in a technical merit of 100 %. For those characteristics that only have a yes-no-option the numbers 1 and 0 were chosen to express these two options - 1 stand for yes, 0 stands for no. So if a alternative is equipped with a certain yes-no-characteristic it will receive $(100 \% * \text{weighting}_{k})$

The following tables list all of the alternatives of each electronic component including the important characteristics of the various components and the weighting of those characteristics, that have a considerable influence on the overall product. Additionally each table is accompanied by a figure that conveys the comparison of the technical merits of each alternative. Some information in the tables is missing because of the lack of available information online.

Microcontrollers

Table 48: Technical merits of different microcontrollers

Nb.	Component	Comments	Price	Mass [g]	Dimensions [mm]	Availability	Processor Speed [MHz]	Cores	Wi-Fi	Technical Merit	Provider
1.	NUCLEO-C031C6	STMicroelectronics	10.31 €	43.2		1	48	1	0	23 %	[Mouser, 2023]
2.	Raspberry Pi 1 Model A+		28.49 €	23.0	66 x 56 x 14	0	700	1	0	23 %	[RS, 2023]
3.	Raspberry Pi 3 Model A+		28.51 €	23.0	67 x 56 x 14	0	1400	4	1	66 %	[RS, 2023]
4.	Raspberry Pi 3 Model B		40.27 €	45.0	85 x 56 x 17	0	1200	4	1	43 %	[DigiKey, 2023]
5.	Raspberry Pi Pico		4.60 €	7.0	51 x 21	1	133	2	0	48 %	[DigiKey, 2023]
6.	Raspberry Pi Pico H	w/ headers	5.76 €	7.0	52 x 21	1	133	2	0	48 %	[DigiKey, 2023]

Nb.	Component	Comments	Price	Mass [g]	Dimensions [mm]	Availability	Processor Speed [MHz]	Cores	Wi-Fi	Technical Merit	Provider
7.	Raspberry Pi Pico W	approx. 70 mA	6.90 €	7.0	53 x 21	1	133	2	1	77 %	[DigiKey, 2023]
8.	Raspberry Pi Pico WH	w/ headers	8.10 €	7.0	54 x 21	0	133	2	1	76 %	
9.	Raspberry Pi Zero 2W		19.19 €	9.0	65 x 30 x 5	0	1000	4	1	76 %	[Electrofun, 2023]
10.	Raspberry Pi Zero W		17.26 €	9.0	66 x 30 x 5	0	1000	1	1	70 %	[DigiKey, 2023]
11.	Raspberry Pi Zero W BCM2835	w/ coded headers	36.08 €	10.0	67 x 30 x 5	0	1000	1	1	55 %	[DigiKey, 2023]
12.	Arduino Nano 33 IoT	w/ headers	28.53 €	12.0		0	48		1	57 %	[Electrofun, 2023]
13.	Arduino Nano RP2040 Connect	incl. IMU	36.71 €	12.0		1	133		1	51 %	[Electrofun, 2023]
		Weighting	30 %	25 %			15 %		30 %		

Figure 51 compares the different microcontrollers.

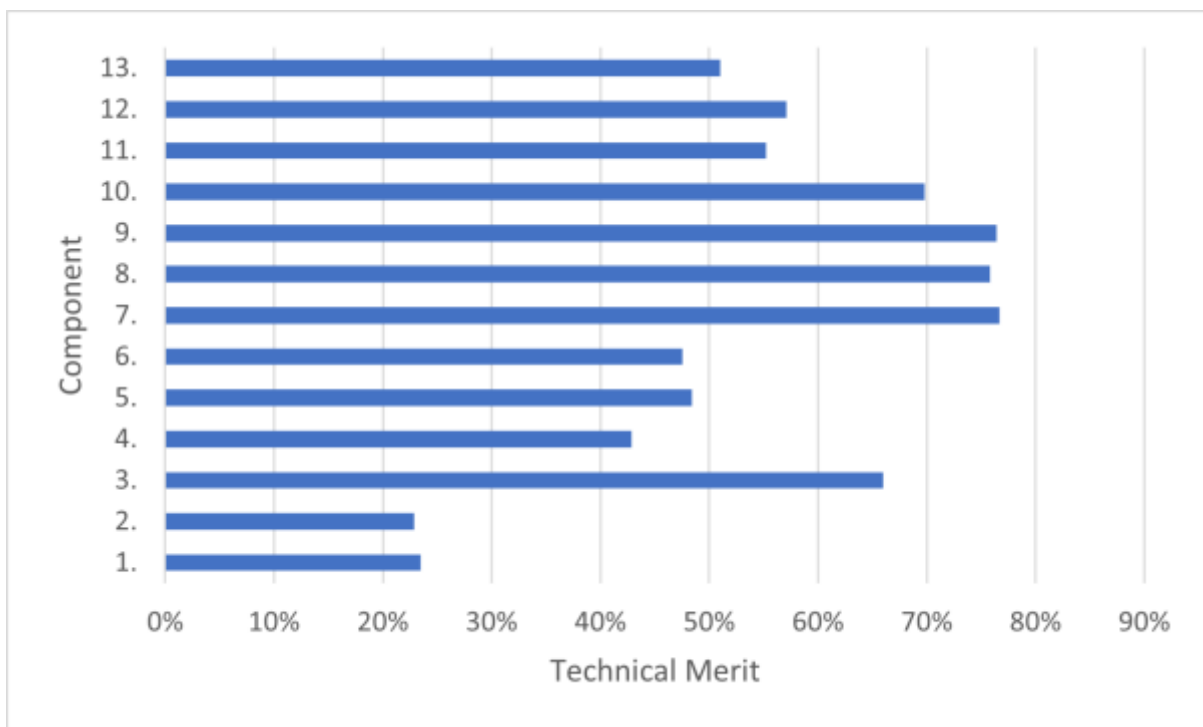

Figure 51: Comparison of the different microcontrollers

Inertial Measurement Unit (IMU)

Table 49: Technical merits of different IMU

Nb.	Component	Comments	Price	Mass [g]	Dimensions [mm]	Availability	DoF	Interface	Technical Merit	Provider
1.	3886 MPU-6050	Adafruit	12.17 €	22,3		1	6	I2C	49 %	[Mouser, 2023]
2.	MIKROE 4086	MIKROELEKTRONIKA	6.84 €	17.0	42.9 x 25.4	1	6	I2C, SPI	66 %	[RS, 2023]
3.	MOD-MPU6050	Olimex Ltd.	6.07 €	37.0		1	6	I2C	43 %	[Mouser, 2023]
4.	SEN0205	DFROBOT	9.11 €	14.0	27 x 22	1	6	I2C	65 %	[Farnell, 2023]

Nb.	Component	Comments	Price	Mass [g]	Dimensions [mm]	Availability	DoF	Interface	Technical Merit	Provider
5.	101020585	SEED STUDIO	10.03 €	10.0		1	9	I2C	68 %	[Farnell, 2023]
6.	STEVAL-MKI194V1	STMICROELECTRONICS	15.51 €	34.0		0	6	I2C	28 %	[Farnell, 2023]
7.	STEVAL-MKI197V1	STMICROELECTRONICS	17.11 €	33.0		1	6	I2C	26 %	[Farnell, 2023]
8.	MIKROE-3447	MIKROELEKTRONIKA	20.24 €	18.0		0	6	I2C, SPI	38 %	[Farnell, 2023]
9.	BMX160 SEN0373	DFROBOT	15.99 €	22.3	20 x 12,5	1	9	I2C, SPI		[DigiKey, 2023]
10.	BNO055 SEN0374	DFROBOT	20.59 €	22.3	19 x 21	1	9	I2C, UART		[DigiKey, 2023]
11.	SEN0386	DFROBOT	28.65 €	22.3	51.3 x 36 x 10	1	6	TTL		[DigiKey, 2023]
12.	MIKROE-4228	MIKROELEKTRONIKA	8.78 €	22.3	38.6 x 25.4	1	6	I2C		[RS, 2023]
13.	MMA8452Q	Xtrinsic, w/ headers	12.79 €	15		0	3	I2C	46 %	[PT Robotics, 2023]
		Weighting	40 %	45 %			15 %			

Figure 52 compares the different IMU.

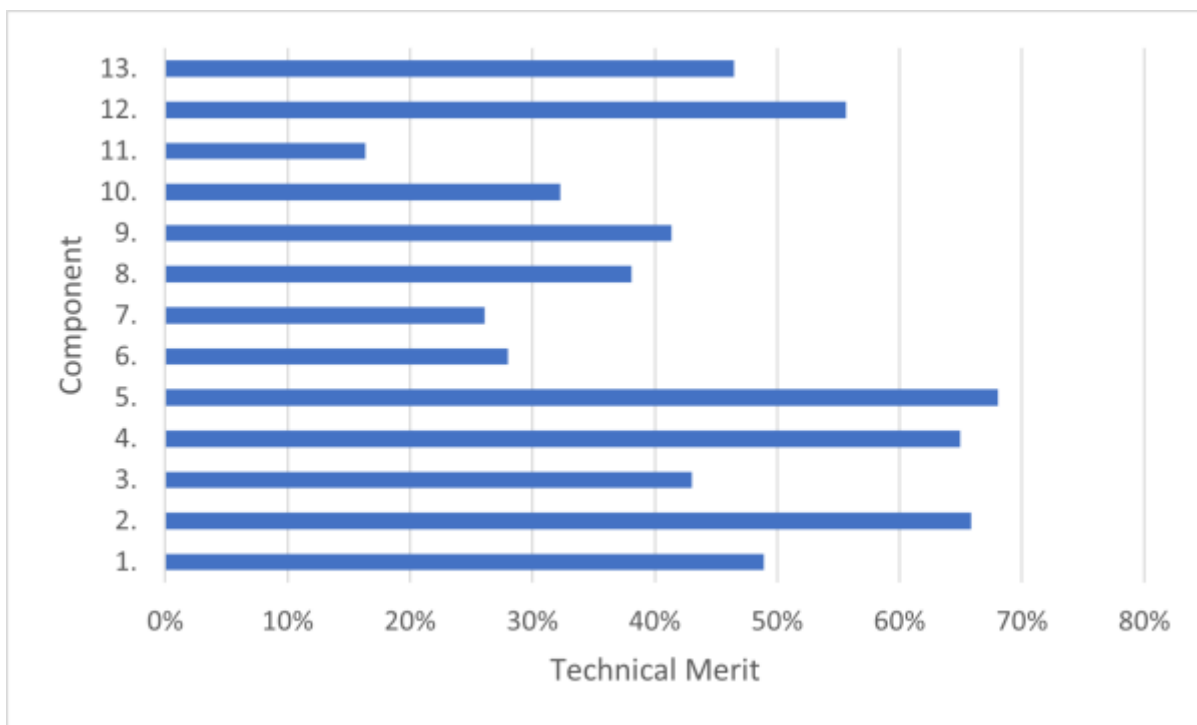

Figure 52: Comparison of the different IMU

Camera

Table 50: Technical merits of different cameras

Nb.	Component	Comments	Price	Mass [g]	Dimensions [mm]	Availability	Photo Resolution [MP]	Video Resolution [MP]	Frame Rate [FPS]	Interface	Thermal Image	Technical Merit	Provider
1.	Raspberry Pi VR 220 Camera	DesignSpark	137.30 €	0.0	35 x 22 x 21,7	1	2.1	2.1	30	CSI-2	0	38 %	[RS, 2023]
2.	CXD5602PWBCAM1E_FG_875612930_P	Sony Spresense	32.90 €	16.0		1	5.1	2.1	30	I2C	0	59 %	[Mouser, 2023]

Nb.	Component	Comments	Price	Mass [g]	Dimensions [mm]	Availability	Photo Resolution [MP]	Video Resolution [MP]	Frame Rate [FPS]	Interface	Thermal Image	Technical Merit	Provider
3.	114990838 Camera Module, Wide Angle	SEED STUDIO	26.66 €	17.0	25 x 24	1	5.0	2.0			0	59 %	[Farnell, 2023]
4.	SC0872 Raspberry Pi Camera Module 3	Raspberry Pi	22.99 €	15.9	25 x 24 x 11.5	1	11.9	2.1	50	CSI-2, I2C	0	73 %	[Farnell, 2023]
5.	SC0874 Raspberry Pi Camera Module 3 Wide	Raspberry Pi	32.18 €	15.9	26 x 24 x 11,5	1	11.9	2.1	50	CSI-2, I2C	0	71 %	[Farnell, 2023]
6.	410-358 Pcam 5C Camera Module, OV5640 Colour Sensor	DIGILENT	47.05 €	22.7	40 x 25	1	5.0	2.1	30	CSI-2	0	53 %	[Farnell, 2023]
7.	RPI 8MP CAMERA BOARD Raspberry Pi Camera Board, Version 2, Sony IMX219 8MP	Raspberry Pi	25.08 €	3.0	25 x 24 x 9	1	8.0	2.1	30	CSI	0	72 %	[Farnell, 2023]
8.	RPI NOIR CAMERA BOARD Raspberry Pi NoIR Camera Board, Version 2, Sony IMX219 8MP	Raspberry Pi, Infrared Photography	25.08 €	3.0	26 x 24 x 9	1	8.0	2.1	30	CSI	0	72 %	[Farnell, 2023]
9.	4407 MLX90640 IR Thermal Camera Breakout Boards	adafruit	73.27 €	3.5	25.7 x 17.7 x 16	1	0.0	0.0	16	I2C	1	22 %	[Mouser, 2023]
10.	4478 OpenMV Cam H7 R1 - MicroPython Embedded Vision Machine Learning - OV7725 Bildsensor	adafruit	122.14 €	5.0		1	0.3	0.0	0	I2C, CAN, USB	0	12 %	[Mouser, 2023]
	Weighting		30 %	10 %			20 %	25 %	15 %				

Figure 53 compares the different cameras.

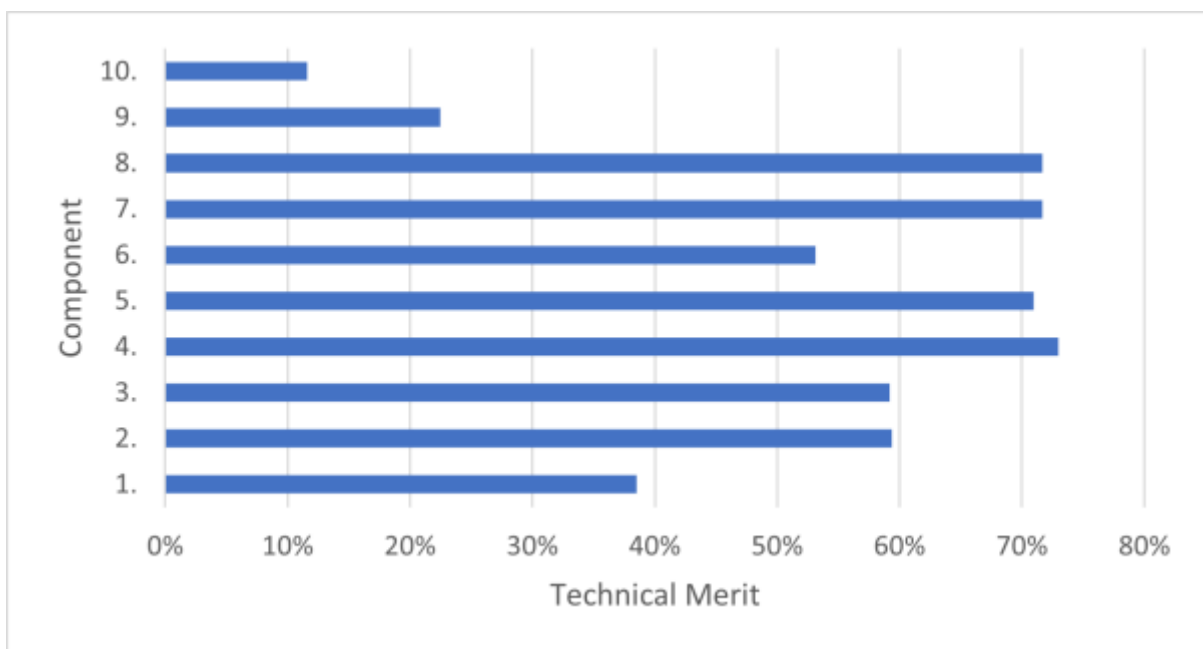

Figure 53: Comparison of the different cameras

Flash Memory

Table 51: Technical merits of different flash memories

Nb.	Component	Comments	Price	Availability	Storage Capacity [Gb]	Writing Speed [Mb/s]	Reading Speed [Mb/s]	Technical Merit	Provider
1.	GLS93MQ001T4-W-BZ804	Greenliant	367.15 €	1	1000	85	100	59 %	[Mouser, 2023]
2.	FIT0643	DFRobot	24.69 €	1	128	10	100	58 %	[Mouser, 2023]
3.	DESDM-C12S06GW1SL	Innodisk	225.27 €	1	512	31	75	46 %	[Mouser, 2023]
4.	MTSD1T0AKC7MS-1WT	Micron	265.07 €	1	1000	39	100	60 %	[Mouser, 2023]
5.	MTSD512AKC7MS-1WT	Micron	147.21 €	1	512	39	100	60 %	[Mouser, 2023]

Nb.	Component	Comments	Price	Availability	Storage Capacity [Gb]	Writing Speed [Mb/s]	Reading Speed [Mb/s]	Technical Merit	Provider
6.	MTSD1T0ANC8MS-1WT	Micron	240.47 €	1	1000	39	100	62 %	[Farnell, 2023]
7.	MTSD256ANC8MS-1WT	Micron	62.95 €	1	256	39	100	63 %	[Farnell, 2023]
8.	INMSDH16G10-90U1	INTEGRAL	5.74 €	1	16	10	90	55 %	[Farnell, 2023]
9.	INMSDX256G-100/90V30	INTEGRAL	23.37 €	1	256	90	100	79 %	[Farnell, 2023]
10.	INMSDH16G-100V10	INTEGRAL	5.21 €	1	16	10	100	57 %	[Farnell, 2023]
11.	SDSQXCG-032G-GN6MA	SanDisk	19.66 €	1	32	90	100	74 %	[Farnell, 2023]
12.	INMSDH32G-100V10	INTEGRAL	5.79 €	1	32	10	100	57 %	[Farnell, 2023]
13.	MB-MP64GA/EU	Samsung	12.68 €	1	64	20	100	60 %	[Farnell, 2023]
		Weighting	40 %		25 %	20 %	15 %		

Figure 54 holds the comparison of the different flash memories.

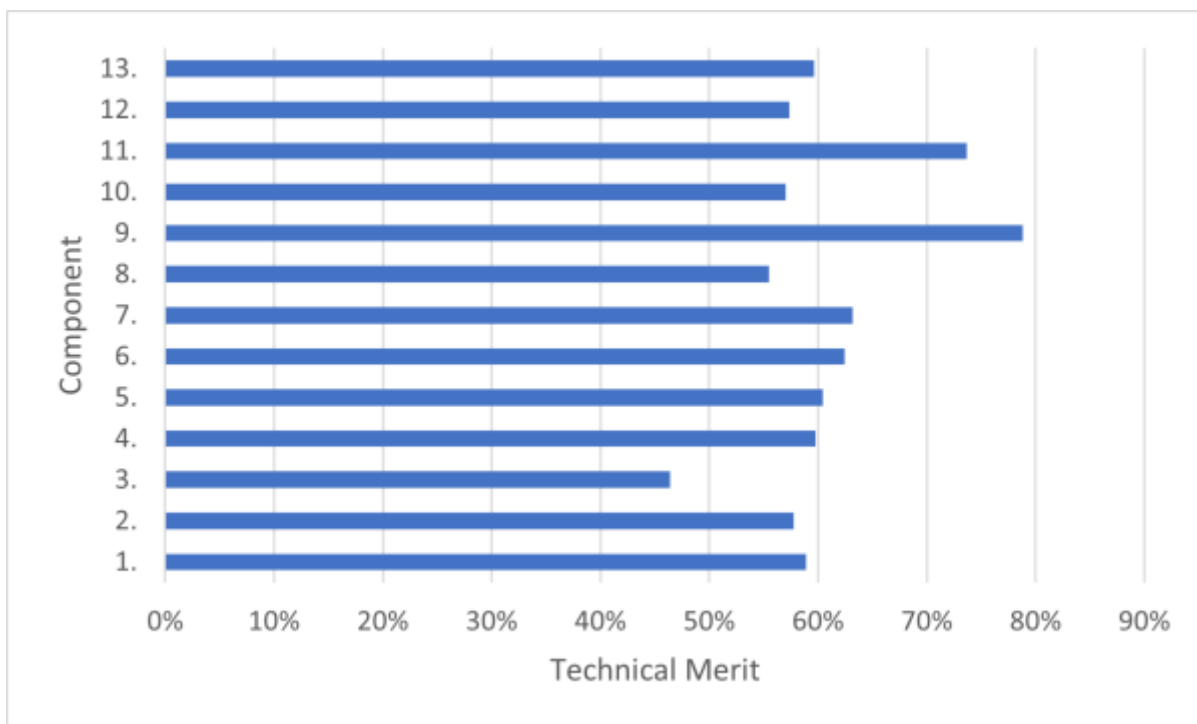

Figure 54: Comparison of the different flash memories

Battery

Table 52: Technical merits of different batteries

Nb.	Component	Comments	Price	Availability	Mass [g]	Dimensions	Capacity [mAh]	Voltage	Continuous Current	Connector	Technology	Technical Merit	Provider
1.	RS PRO LiPo 125-1266	RS Pro	21.11 €	1	40	60 x 7 x 43.5	2000	3.7 V / 3.0	0.5 C	JST HXP-2	LiPo	62 %	[RS, 2023]
2.	RS PRO 777-0374	RS Pro	18.63 €	1	105		1300	6.0	0.2 C	no	NiMH	56 %	[RS, 2023]
3.	RS PRO 777-0403	RS Pro	24.78 €	1	125	14.3 x 65	2000	6.0	0.2 C	no	NiMH	50 %	[RS, 2023]

Nb.	Component	Comments	Price	Availability	Mass [g]	Dimensions	Capacity [mAh]	Voltage	Continuous Current	Connector	Technology	Technical Merit	Provider
4.	RS PRO 917-5920	RS Pro	32.16 €	1	195	D19 x 201	4000	3.6	0.2 C	no	NiMH	40 %	[RS, 2023]
5.	RS PRO 204-2752	RS Pro	26.58 €	1	450	D33.5 x 236	4000	4.8		AMP	NiCd	16 %	[RS, 2023]
6.	RS PRO 144-9409	RS Pro	36.51 €	1	183	73 x 68 x 19	10400	3.7		no	Li-Ion	50 %	[RS, 2023]
7.	RS PRO 144-9408	RS Pro	29.75 €	1	138	69 x 55 x 19	7800	3.7		no	Li-Ion	55 %	[RS, 2023]
8.	RS PRO 144-9407	RS Pro	23.23 €	1	93	69 x 36 x 19	5200	3.7		no	Li-Ion	61 %	[RS, 2023]
9.	4DH4-0LAP3	Yuasa	21.40 €	1	126		4000	4.8		AMP	NiCd	56 %	[RS, 2023]
10.	4DH4-0LA4	Yuasa	23.00 €	1	126		4000	4.8		AMP	NiCd	55 %	[RS, 2023]
11.	035-3918		28.40 €	1	153	123 x 72 x 10	10000	3.7	0.2 C	JST or AMP?	LiPo	59 %	[Mauser, 2023]
12.	BAT01040		21.60 €	1	74	8.5 x 50.5 x 80.5	4000	3.7	1 C	JST or AMP?	LiPo	62 %	[botnroll, 2023]
13.	PTR011201		32.10 €	1	176.46	9.4 x 71 x 129.5	10000	3.7	0.2 C	JST SYR-02T	LiPo	53 %	[PT Robotics, 2023]
	Weighting		30 %		50 %		20 %						

Figure 55 displays the comparison of the different batteries.

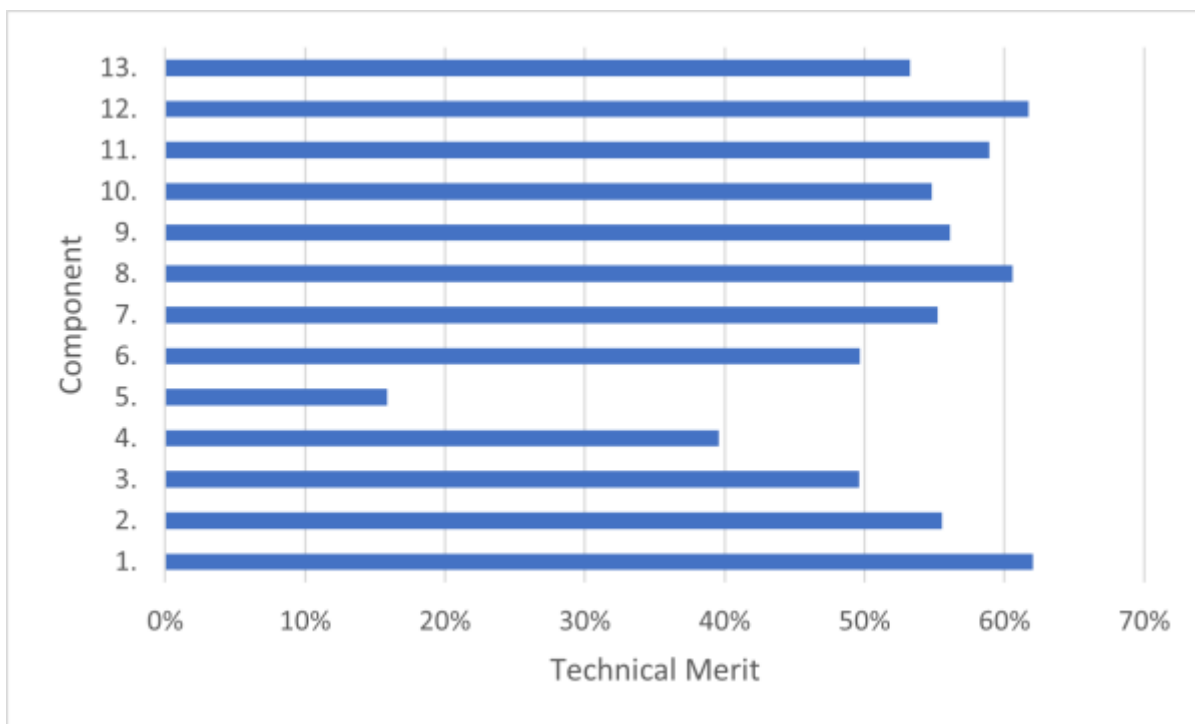

Figure 55: Comparison of the different batteries

Propulsion Motors

Table 53: Technical merits of different DC motors

Nb.	Component	Comments	Price	Availability	Mass [g]	Dimensions	KV [min-1/V]	max. Voltage [V]	max. Current [mA]	Torque [Nm]	RPM [min-1]	Technology	Technical Merit	Provider
1.	MIKROE-4035	MIKROE	11.28 €	1	12	12 x 10 x 35.3		6	60	4.90E-03	430	BDC	61 %	[Mouser, 2023]
2.	M1G10	MinebeaMitsumi	49.05 €	0	13	14 x 12 x 35.35		5.0	138	9.10E-03	567	BDC	26 %	[Mouser, 2023]
3.	MOT02105		9.50 €	1	47	27.5 x 27.5 x 30	1400	11.1	12000		15540	BLDC	56 %	[botnroll, 2023]
4.	MOT02019	Shenzhen Kinmore Motor Co., Ltd	9.90 €	1	10			6.0	135	1.47E-02	95	DC	63 %	[botnroll, 2023]

Nb.	Component	Comments	Price	Availability	Mass [g]	Dimensions	KV [min-1/V]	max. Voltage [V]	max. Current [mA]	Torque [Nm]	RPM [min-1]	Technology	Technical Merit	Provider
5.	MT2204	Emax	14.70 €	1	25	27.9 x 27.9 x 32.2	2300	8.0	6400		11910	BLDC	63 %	[PT Robotics, 2023]
		Weighting	45 %		35 %						20 %			

Figure 56 shows the comparison of the different dc motors.

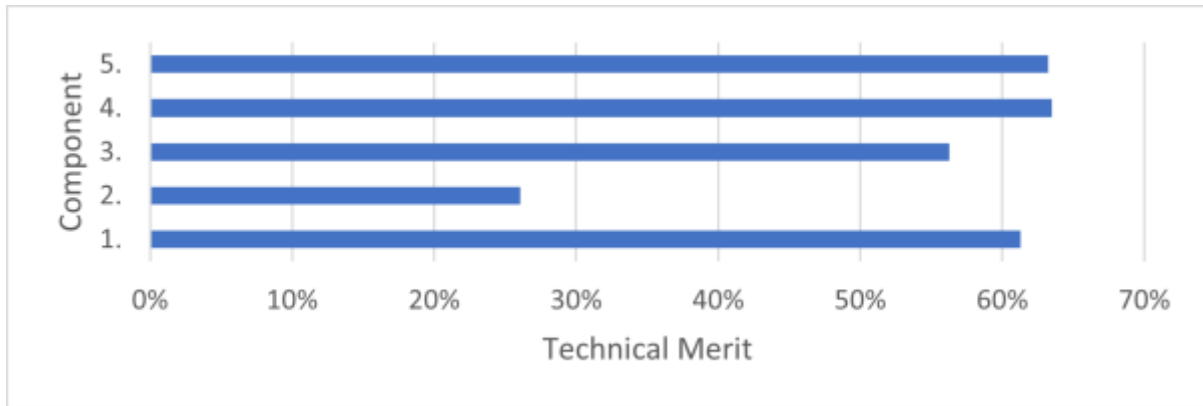

Figure 56: Comparison of the different dc motors

Servo Motors

Table 54: Technical merits of different servo motors

Nb.	Component	Comments	Price	Availability	Mass [g]	Dimensions	max. Voltage	max. Current	Range	Torque [Nm]	RPM	Technical Merit	Provider
1.	SER0002	DFRobot	24.03 €	1	45.36	19.81 x 39.88	6	180	360	4.02E-01		19 %	[DigiKey, 2023]
2.	1142	Adafruit Industries LLC	22.57 €	1	62.6	40 x 20			170	9.89E-01		14 %	[DigiKey, 2023]
3.	ROB-09347	SparkFun Electronics	16.91 €	1	44	20.5 x 42 x 39.5	6		360	4.71E-01	70	37 %	[DigiKey, 2023]
4.	SER0038	DFRobot	16.85 €	1					180			57 %	[DigiKey, 2023]
5.	SER0011	DFRobot	7.81 €	1	14.7	23 x 12 x 28.8	6			2.45E-01		61 %	[DigiKey, 2023]
6.	ROB-16413	SparkFun Electronics	7.49 €	1	44	34.44 x 25.2 x 79.95	9		360		90	47 %	[DigiKey, 2023]
7.	900-00008	Parallax Inc.	25.81 €	1	42.5	55.8 x 19 x 40.6	6	190	360	2.68E-01	50	22 %	[RS, 2023]
8.	MG90S 360		9.77 €	0	14	23 x 12.2 x 29	6		360	2.16E-01	100	69 %	[Electrofun, 2023]
		Weighting	35 %		45 %					10 %	10 %		

Figure 57 presents the comparison of the different servo motors.

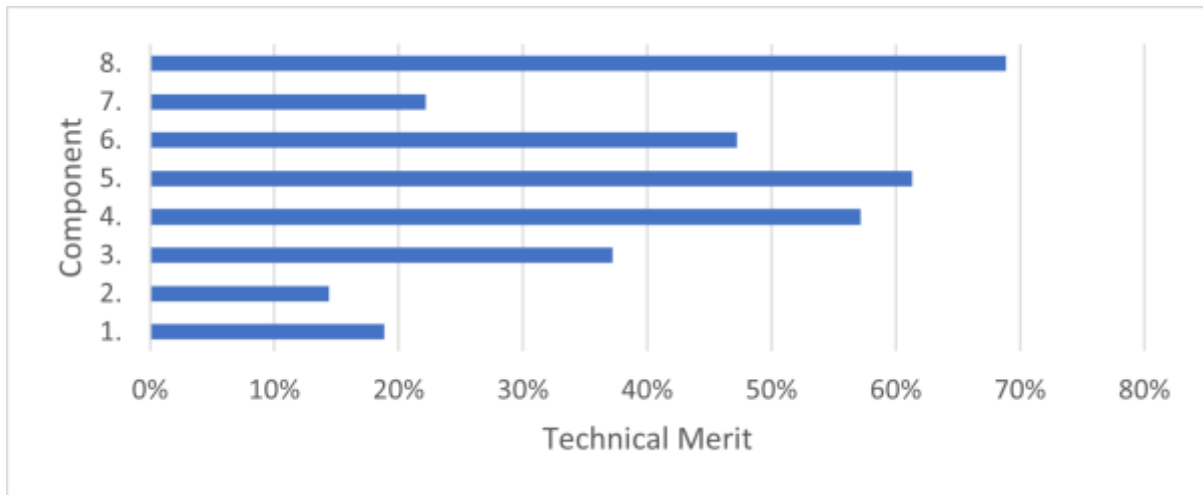

Figure 57: Comparison of the different servo motors

GNSS Sensor

Table 55: Technical merits of different GNSS (Global Navigation Satellite System) sensors

Nb.	Component	Comments	Price	Availability	Mass [g]	Voltage [V]	Current [mA]	Channels	GNSS-Systems	Precision [m]	Frequency [GHz]	Interface	Technical Merit	Provider
1.	MOD-GPS	Olimex Ltd.	21.37 €	1	110	3,3	38	20	GPS		L1		43 %	[Mouser, 2023]
2.	3133	Adafruit	23.45 €	1	8.8	3.3	20	66		1.8		UART	69 %	[Mouser, 2023]
3.	109020022	Seed-Studio	12.31 €	1	10	3.3 - 5	60		GPS/Beidou/Glonass/Galileo/QZSS/SBAS	2.5		UART	74 %	[Mouser, 2023]
4.	TEL0138	DFRobot	11.83 €	1	25	5.0		56		2.5	L1/L2/L3	USB	69 %	[RS, 2023]
5.	746	Adafruit	44.62 €	1	38	3.3 - 5	20	66				I2C	51 %	[RS, 2023]
6.	113020003	Seed-Studio	24.88 €	1	38	3.3	40	50		5		USB/UART/SPI	42 %	[RS, 2023]
7.	SEN09004		18.85 €	1	38	3.3 - 5	11	99	GPS, BDS, QZSS	2.5	L1/B1	UART	59 %	[botnroll, 2023]
		Weighting	35 %		40 %					25 %				

Figure 58 holds the comparison of the different GNSS sensors.

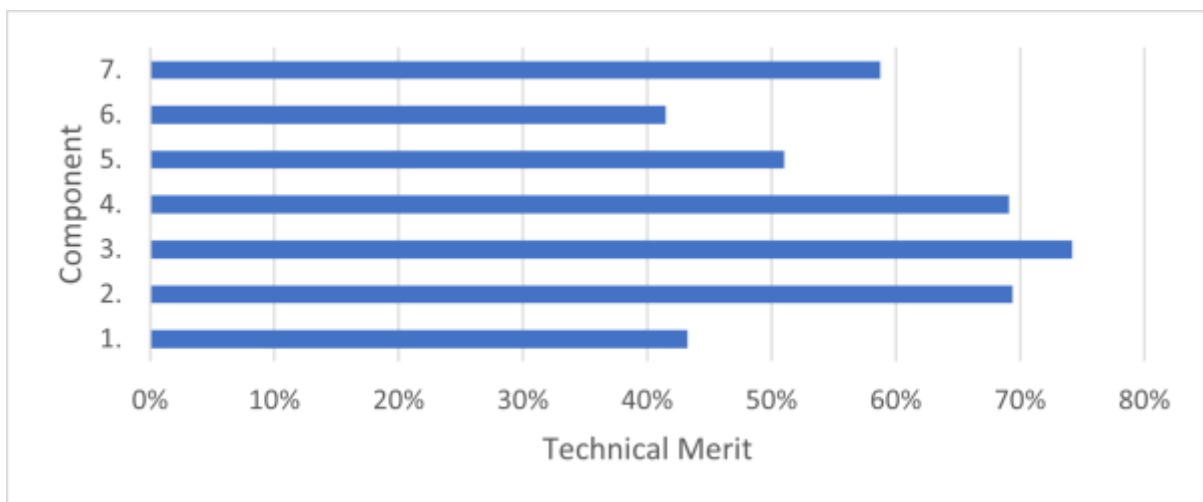

Figure 58: Comparison of the different GNSS sensors

Electronic Speed Control (ESC)

Table 56: Technical merits of different ESC

Nb.	Component	Comments	Price	Availability	Mass [g]	Voltage [V]	Current [A]	Technology	Technical Merit	Provider
1.	B-G431B-ESC1	STMicroelectronics	18.01 €	1	51.26	22.2	40	BLDC	29 %	[Mouser, 2023]
2.	STEVAL-ESC002V1	STMicroelectronics	30.55 €	1	6.8	22.2	20	BLDC	26 %	[Mouser, 2023]
3.	I0023BG	ElectroFun	11.47 €	0	25	16.8	30	BLDC	59 %	[Electrofun, 2023]
4.	MOT01030		5.50 €	1	3	10.0	1.5	BDC	86 %	[botnroll, 2023]
5.	DRV8838	Texas Instruments	10.60 €	1	3	11.0	1.8	BDC	74 %	[botnroll, 2023]
		Weighting	70 %		30 %					

Figure 59 compares the different ESC.

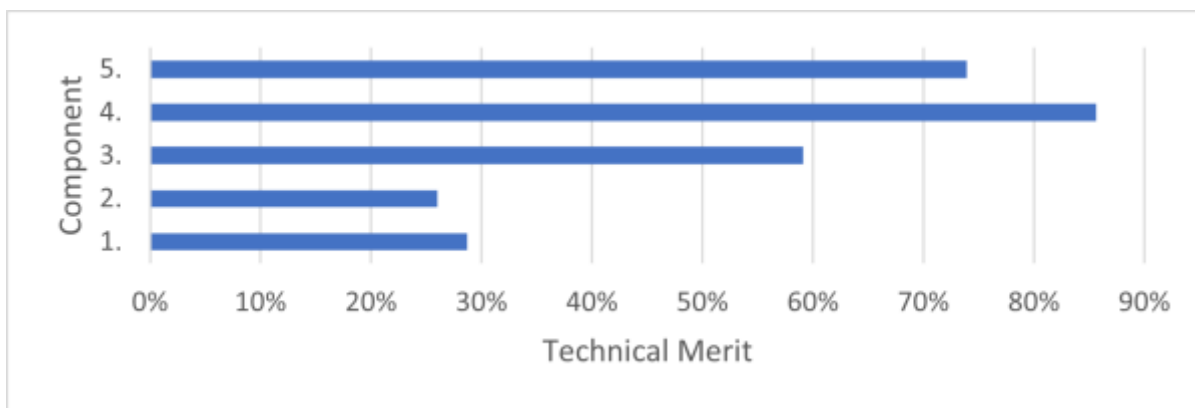

Figure 59: Comparison of the different ESC

Power Budget

According to the comparisons above, the best suitable electronic components are chosen. Additionally to the technical merit there are other factors that have to be taken into consideration, like the type of interface(s) for each component. Because of this, the microcontroller with the best technical merit - the Raspberry Pi Pico W - will not be used in the final product, due to it's lack of interfaces. This is also the case for all other Raspberry Pi Picos and the Arduino Nano RP2040 Connect. The use of the NUCLEO-C031C6 is not advisable as well, since it has no WiFi (Wireless Fidelity) module. Instead the Raspberry Pi Zero 2W will be used to fulfil the computational tasks of the blimp. This microcontroller is equipped with the needed interfaces and a WiFi module.

Table 57 lists all the electronic components that will make up the final product. The maximum power consumption is approximately 23 W.

Table 57: Power Budget

Nb.	Component	Description	Amount	Interface	Mass [g]	max. Voltage [V]	max. Current [mA]	max. Power [W]
1.	Raspberry Pi Zero 2W	µC	1	Mini HDMI, CSI-2, microSD	9	5	2500	12,50
2.	101020585	IMU	1	I2C	10	5	0,24	0,00

Nb.	Component	Description	Amount	Interface	Mass [g]	max. Voltage [V]	max. Current [mA]	max. Power [W]
3.	SC0872 Raspberry Pi Camera Module 3	Camera	1	CSI-2, I2C	15,9	3,6	250	0,90
4.	MIKROE-4035	BDC Motor	2	connected to ESC	12	6	60	0,72
5.	MG90S 360	Servo Motor	1	PWM	14	6	60	0,36
6.	109020022	GNSS Sensor	1	UART	10	5	60	0,30
7.	MOT01030	ESC	2	PWM	3	5	3	0,03
						\\(\sum\\)	2996,24	14,81

Figure 60 presents the diagram of the component-wise power consumption.

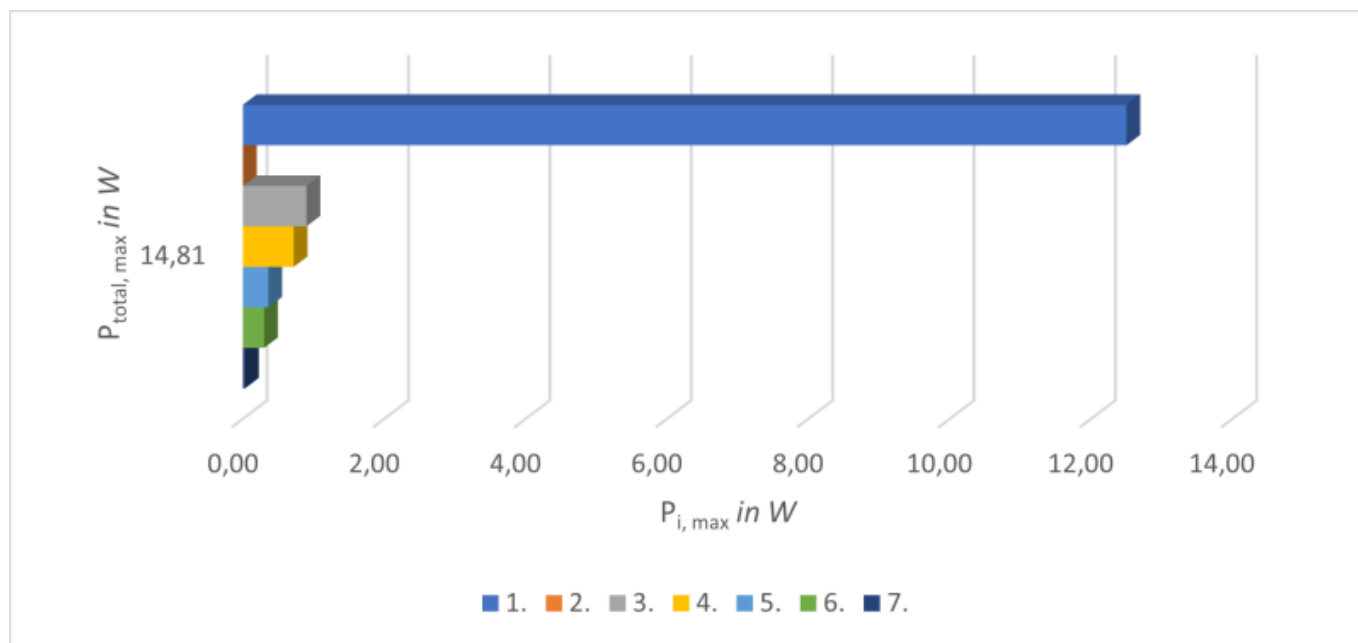

Figure 60: Diagram of the component-wise power consumption

Graybox Diagram

The graybox diagram in Figure 61 is, compared to the black box diagram, a more precise, but still schematic description of the overall product. The biggest differences consist of the detailed listing of the sensors to be used, the expansion of the individual components of the propulsion unit and the addition of the mobile network. The last difference determines the type of communication technology. The sensor system consists of GPS, gyroscope, acceleration sensor and camera while the drive unit consists of a propeller, a motor that drives it, another motor for the angle control of the other motor and the Electronic Speed Control (ESC). Furthermore, a rechargeable battery was specified as the energy source.

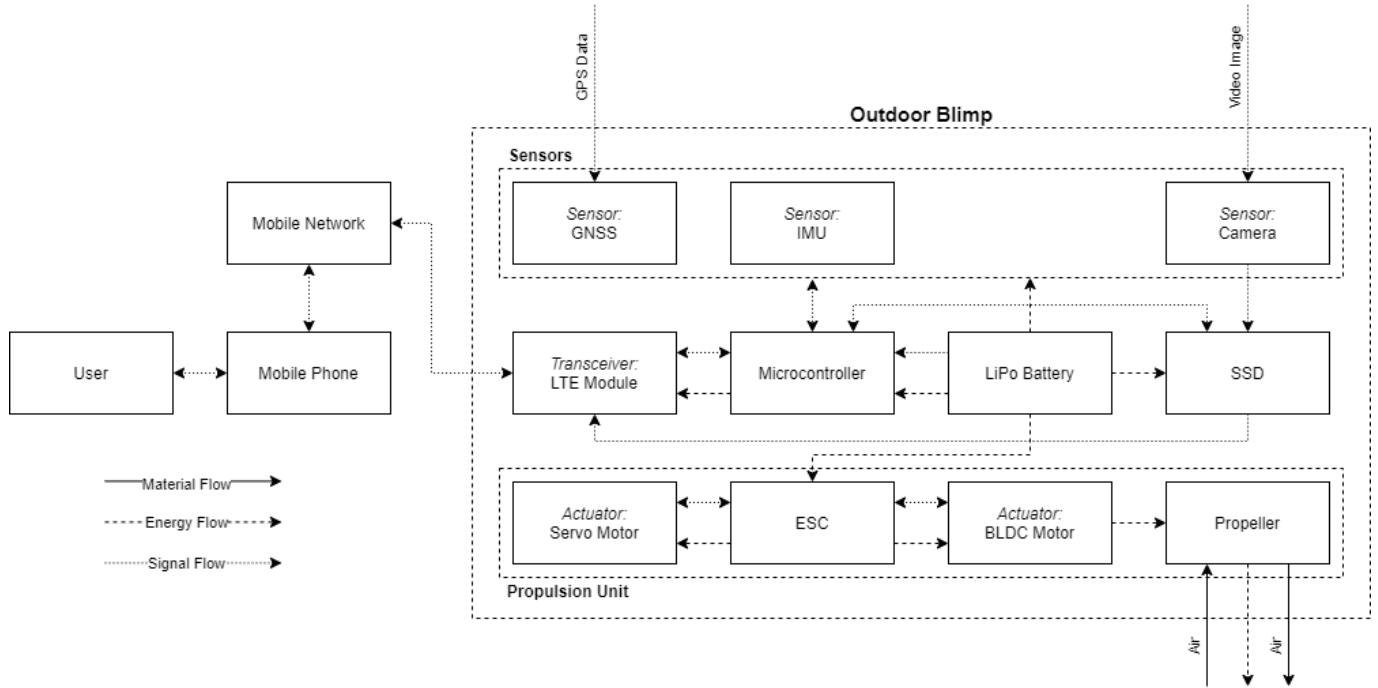

Figure 61: Graybox diagram of the outdoor blimp

System Schematics

Figure 62 displays the schematic layout, including the wiring of the hardware components.

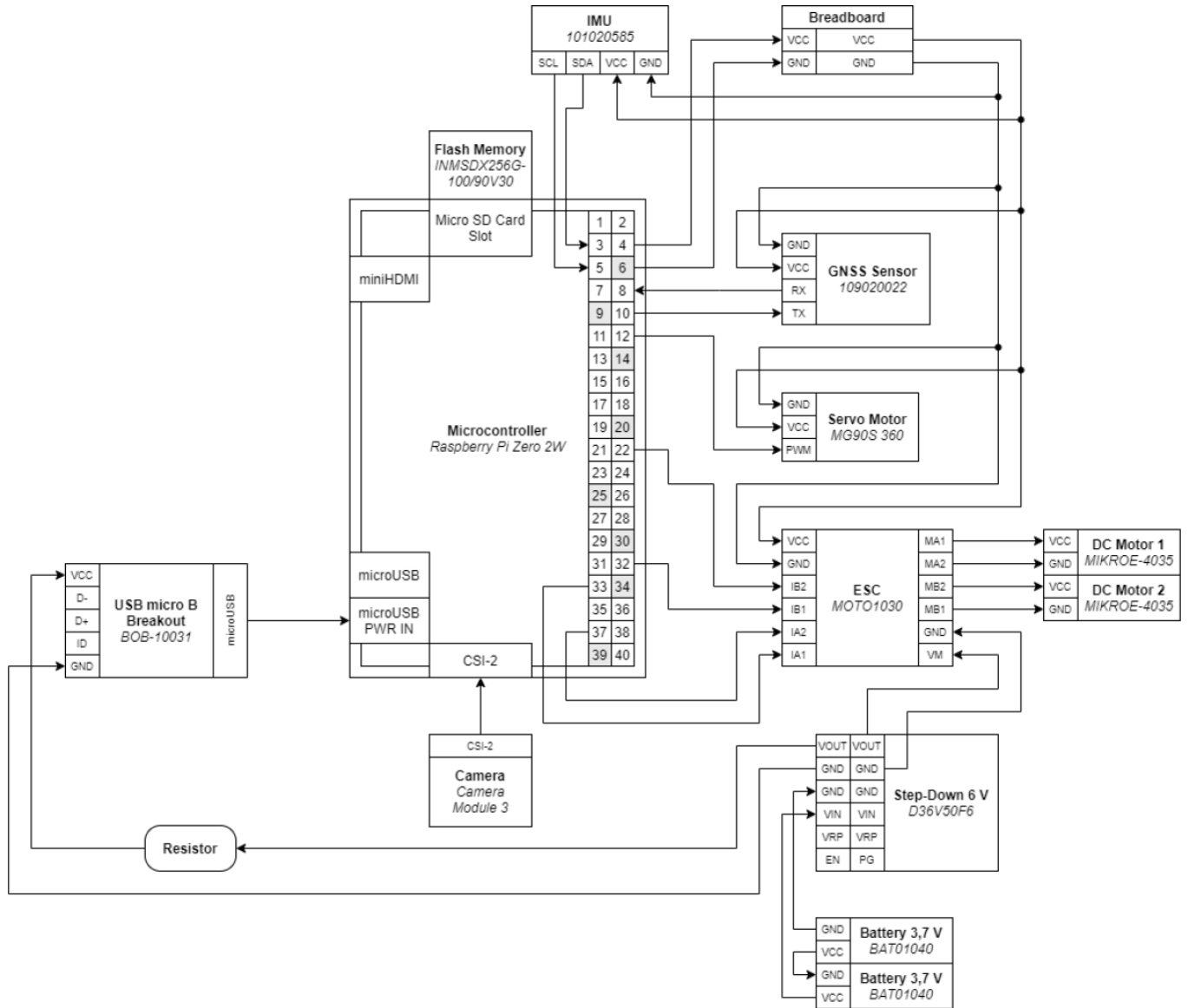

Figure 62: Schematic layout of the hardware components

Electronic Components Used

Table 58 presents the used electronic components.

Table 58: List of the used electronic components

Nb.	Component	Description	Price	Mass [g]	Amount	Provider
1.	Raspberry Pi Zero 2W	Microcontroller	19.19 €	9	1	[Electrofun, 2023]
2.	101020585	IMU	10.03 €	10	1	[Farnell, 2023]
3.	SC0872 Raspberry Pi Camera Module 3	Camera	22.99 €	15.9	1	[Farnell, 2023]
4.	INMSDX256G-100/90V30	Flash Memory	23.37 €	1	1	[Farnell, 2023]
5.	BAT01040	Battery	21.60 €	74	2	[botnroll, 2023]
6.	MIKROE-4035	DC Motor	11.28 €	12	2	[Mouser, 2023]

Nb.	Component	Description	Price	Mass [g]	Amount	Provider
7.	MG90S 360	Servo Motor	9.77 €	14	1	[Electrofun, 2023]
8.	109020022	GNSS Sensor	12.31 €	10	1	[Mouser, 2023]
9.	MOT01030	ESC	5.50 €	3	1	[botnroll, 2023]
10.	D36V50F6 - Step Down	Step Down	22.57 €	7	1	[PT Robotics, 2023]
11.	BOB-10031	USB Micro B Breakout	4.55 €	2.2	1	[DigiKey, 2023]
		\\(\sum\\)	163.16 €	158.1		

Software

User stories web application

Table 59 you will find user story 1.

Table 59: User story 1

User story	As a farmer, I want to be able to log into the application, so that I can access the blimp monitoring system.
Acceptance criteria	Given the user is on the login page, When the user enters their valid login credentials and clicks the login button, Then the system should verify the credentials and allow the user to log in.
	Given the user has successfully logged in, When the system has verified their credentials and redirected them, Then the user should be taken to the blimp monitoring system page.
	Given the user is on the login page, When the user enters invalid login credentials and clicks the login button, Then the system should display an appropriate error message and prompt the user to re-enter their credentials.

Table 60 you will find user story 2.

Table 60: User story 2

User story	As a farmer, I want to be able to log out of the application, so that I can leave the blimp monitoring system.
-------------------	--

Acceptance criteria	Given the user is logged in to the application, When the user clicks the logout button on any page of the application, Then the system should log the user out and redirect them to the login page.
	Given the user has successfully logged out, When the user tries to access any page of the application, Then the system should prompt the user to log in again.
	Given the user has logged out of the application, When the user tries to access any page of the application without logging in again, Then the system should redirect the user to the login page and prevent access to any other pages until the user has successfully logged in again.

Table 61 you will find user story 3.

Table 61: User story 3

User story	As a farmer, I want to be able to view a map of the area where my blimps are located, so that I can see their locations.
Acceptance criteria	Given the user is on the blimp monitoring system page, When the user clicks on the "Map" button, Then the system should display a map showing the locations of all the blimps.
	Given the map is displayed, When the user interacts with the map by zooming in/out or panning, Then the system should allow the user to manipulate the map accordingly.
	Given the user is on the map page, When the user clicks on a blimp marker, Then the system should display more information about the blimp, such as its name, location, and status.
	Given the user has clicked on a blimp marker, When the user is finished viewing the blimp information, Then the system should allow the user to return to the map with all blimp markers visible.

Table 62 you will find user story 4.

Table 62: User story 4

User story	As a farmer, I want to be able to view information about a particular blimp, so that I am informed.
Acceptance criteria	Given the user is on the blimp monitoring system page, When the user clicks on a blimp marker, Then the system should display more information about the blimp, such as its name, location, and status.

	Given the user has clicked on a blimp marker, When the system displays the blimp information, Then the information should be presented in a clear and easily understandable way, such as using labels, icons, and short descriptions.
	Given the user has finished viewing the blimp information, When the user clicks the "Close" button, Then the system should close the information window and allow the user to continue using the blimp monitoring system.

Table 63 you will find user story 5.

Table 63: User story 5

User story	As a farmer, I want to be able to move a blimp to a new location on the map, so that I can monitor different areas of my farm.
Acceptance criteria	Given the user is on the blimp monitoring system page, When the user clicks and drags a blimp marker to a new location on the map, Then the system should update the blimp's location in real-time as the user drags the marker.
	Given the user has finished dragging the blimp marker to a new location, When the user releases the mouse button, Then the system should save the blimp's new location in the system.
	Given the user has moved a blimp to a new location, When the user refreshes the page or logs out and logs back in, Then the system should display the blimp's new location on the map.
	Given the user has moved a blimp to a new location, When the system displays the blimp information, Then the information should show the blimp's new location and update the system with the new location information.

Table 64 you will find user story 6.

Table 64: User story 6

User story	As a farmer, I want to be able to view a live stream of the camera attached to the blimp, so that I can monitor my animals in real-time.
Acceptance criteria	Given the user is on the blimp information page When the user clicks on the "Live Stream" button Then the system should provide a live stream of the camera attached to the blimp.

Table 65 you will find user story 7.

Table 65: User story 7

User story	As a farmer, I want to be able to add a new blimp, so that I can expand my animal monitoring capabilities.
Acceptance criteria	Given a user wants to add a new blimp to the system, When the user clicks on the "Add Blimp" button, Then the system should display a map with a marker at the user's current location.

Table 66 you will find user story 8.

Table 66: User story 8

User story	As a farmer, I want to be able to delete a blimp from the system, so that I can remove old or broken blimps from my inventory.
Acceptance criteria	Given the user is logged in and on the blimp list page, When the user clicks on the "Delete" button next to a blimp, Then a confirmation dialog should be displayed asking the user if they are sure they want to delete the blimp.

Table 67 you will find user story 9.

Table 67: User story 9

User story	As a farmer, I want to be able to update information about a blimp, so that I can customize my monitoring system to my needs.
Acceptance criteria	Given the user is logged in and has accessed the blimp information page, When the user clicks on an "Edit" button next to a blimp's information, Then the system should display a form that allows the user to edit the blimp's information, such as name, location, and monitoring details.
	Given the user has edited the blimp's information, When the user clicks on a "Save" button to save the changes, Then the system should save the updated information in the system.
	Given the user has made an error in the blimp's information form, When the user tries to save the changes by clicking on the "Save" button, Then the system should display an error message informing the user of the error and preventing the changes from being saved until the error is corrected.

Table 68 you will find user story 10.

Table 68: User story 10

User story	As a farmer, I want to be able to get notification when a blimp is out of range, so that I am informed of any errors
-------------------	--

Acceptance criteria	Given a blimp is out of range, When the system detects it, Then the system should send a notification to the user, And the notification should include the blimp's name and location, And the notification should indicate that the blimp is out of range.
----------------------------	--

The use case diagram can be found in Figure 63.

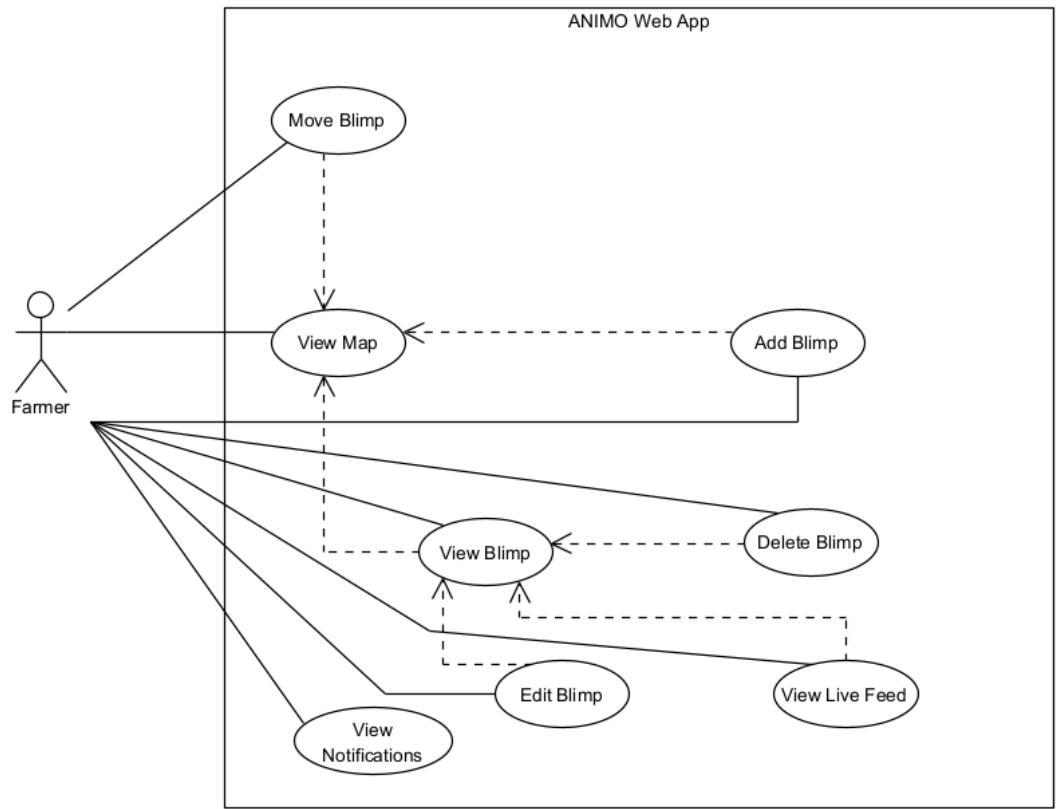

Figure 63: Use case application

Selection of development platforms and software components

Front-end

Table 69: Top 5 front-end technologies

Technology	Language	Platform	Performance	Popularity	Learning curve
Reactive Native	JavaScript	iOS & Android	Good	Very popular	Moderate
Flutter	Dart	iOS & Android	Excellent	Increasingly Popular	Moderate
Xamarin	C#	iOS & Android	Good	Popular	Steep
Ionic	JavaScript	iOS & Android	Moderate	Popular	Easy
NativeScript	JavaScript/TypeScript	iOS & Android	Good	Growing in popularity	Moderate

Table 69 compares the top 5 front-end technologies. We have opted to use Ionic for our front-end development for several reasons. First off, we are familiar with Ionic and have used it before. Secondly, Ionic is a cross-platform technology, which means it can be used to develop applications for multiple platforms, including iOS, Android, and web-based applications. Additionally, the large Ionic community gives us access to a variety of materials and information. Additionally, we can easily create an attractive application thanks to Ionic's pre-built UI components. Finally, Ionic is built on top of the powerful Angular framework, in which we have knowledge, which is the most compelling reason for our selection of Ionic.

Back-end

Table 70: Top 5 back-end technologies

Technology	Language	Performance	Scalability	Popularity	Learning Curve
Node.js	JavaScript	Excellent	Good	Very popular	Moderate
Django	Python	Good	Good	Popular	Moderate
Ruby on Rails	Ruby	Good	Good	Popular	Moderate
Spring	Java	Good	Excellent	Popular	Steep
Laravel	PHP	Good	Good	Popular	Moderate

Table 70 lists the top 5 back-end technologies. We have decided to use Spring as our back-end technology for several reasons. First and foremost, we are familiar with Spring and have prior experience dealing with it. Additionally, Spring's modular design allows for easy configuration and customisation. There is a great amount of online resources and help available thanks to the big and active Spring community. Furthermore, because it is built on Java, which is a widely used programming language in the sector, Spring may be easily linked with other Java-based technologies. Last but not least, Spring includes built-in security capabilities that are crucial for guarding against common security flaws and protecting sensitive data.

Database

Table 71: Top 5 database technologies

Technology	Type	Scalability	Performance	Popularity	Learning Curve
PostgreSQL	Relational	Excellent	Good	Popular	Moderate
MongoDB	NoSQL	Good	Good	Very Popular	Moderate
MySQL	Relational	Good	Good	Popular	Easy
Oracle Database	Relational	Excellent	Excellent	Popular	Steep
Redis	NoSQL	Good	Excellent	Growing in Popularity	Easy

Table 71 holds the top 5 database technologies. We have decided to use MySQL as our database technology for several reasons. Firstly, MySQL is an open-source database, which means that it's free to use and can be modified to fit specific project requirements. Additionally, MySQL is highly scalable and provides fast performance, making it suitable for large-scale applications.

Two significant reasons for choosing MySQL are its compatibility with various programming languages

and its use as a relational database. Being compatible with multiple programming languages enables easy integration with other technologies. Meanwhile, the use of a relational database provides a structured and organised way of storing and retrieving data, making it easier to manipulate and extract information.

Cloud

Table 72: Top 5 Cloud technologies

Technology	Type	Deployment Models	Scalability	Popularity	Learning Curve
Amazon Web Services (AWS)	Public cloud	IaaS, PaaS, SaaS	Excellent	Very popular	Steep
Microsoft Azure	Public cloud	IaaS, PaaS, SaaS	Excellent	Popular	Moderate
Google Cloud Platform (GCP)	Public cloud	IaaS, PaaS, SaaS	Excellent	Moderate	Moderate
IBM Cloud	Public cloud	IaaS, PaaS, SaaS	Good	Moderate	Moderate
Alibaba Cloud	Public cloud	IaaS, PaaS, SaaS	Good	Easy	Moderate

Table 72 holds the top 5 cloud technologies. We have selected Amazon Web Services (AWS) as our cloud technology for several reasons. First off, we are familiar with AWS, so we can get started on our project right away. AWS is a flexible platform that can be utilized for a wide range of applications because it also provides a huge selection of services.

Another advantage of AWS is its scalability, which allows for efficient resource utilization and cost savings. AWS also offers a high level of security for our project with its strong security infrastructure and various layers of defence, which include firewalls, encryption, and identity and access control.

Lastly, AWS has a global presence with data centres located in different regions, making it easy to deploy applications in multiple locations and ensuring low-latency access for users.

Authentication

Table 73: Top 5 Authentication platforms

Technology	Type	Security	Popularity	Integration	Learning Curve
Auth0	Identity management	Excellent	Very popular	Wide range	Moderate
Okta	Identity management	Excellent	Popular	Wide range	Moderate
Azure Active Directory	Identity management	Excellent	Popular	Widely supported	Moderate
AWS Cognito	Identity management	Good	Growing in popularity	Widely supported	Moderate
Ping Identity	Identity management	Excellent	Popular	Wide range	Moderate

Table 73 contains the top 5 authentication technologies. For a number of reasons, we have chosen Auth0 as our platform for authentication. First off, Auth0 provides a variety of authentication alternatives, such as passwordless authentication, social logins, and multi-factor authentication. This enables us to offer our users a safe and easy login process.

Second, because Auth0 is so flexible, we can adjust the authentication procedure to meet the requirements of each individual project. It also provides a strong security infrastructure, including tools for breach detection, brute force protection, and anomaly detection. Additionally, Auth0 offers a sizeable developer community and a great amount of documentation, making it simple to locate resources and request support when needed. Additionally, it provides a straightforward interface that makes it easier to integrate authentication into our program.

Last but not least, Auth0 makes it simple to integrate with other technologies, including databases and API, making it straightforward to utilise in conjunction with other tools and services we may need to employ. Overall, we think that Auth0 is a flexible and trustworthy authentication platform that will satisfy the needs of our project.

Component diagram

Figure 64 contains the component diagram.

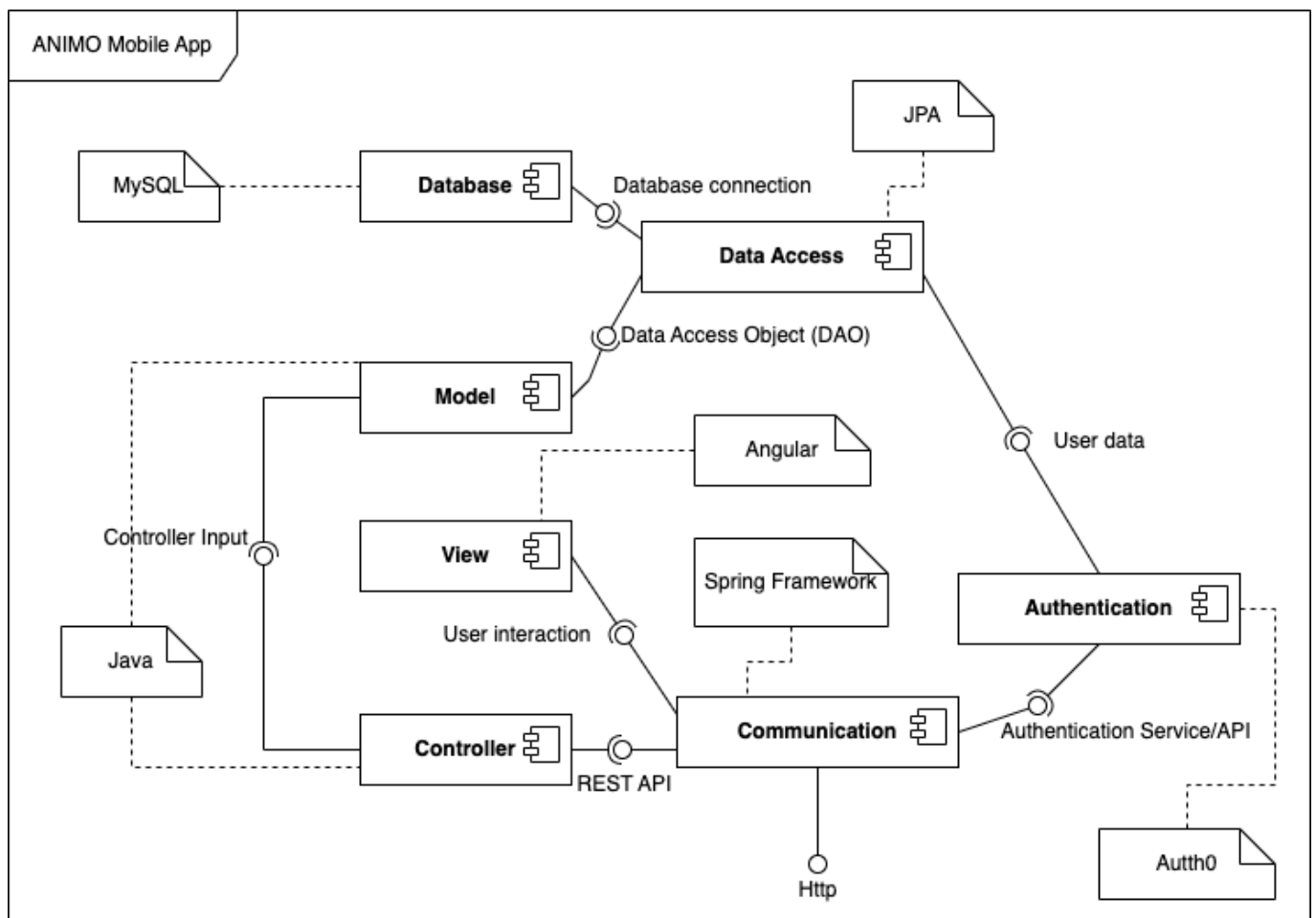

Figure 64: Component diagram

7.4.3 Packaging

7.4.3.1 Initial packaging draft

The product's packaging was made to be reusable, user-friendly, and environmentally responsible. As agriculture is a sector that significantly depends on the environment and sustainability, it was crucial to take the environmental impact of the packaging into consideration. As a result, the design and material selection were carefully considered in order to reduce waste and extend the shelf life of the package.

Using recycled cardboard for the blimp packaging was one of the suggestions made to make the packing environmentally friendly. This decision would be good for the environment because it would lessen waste and offer used materials a second chance. The package might potentially be used as a planting pot for herbs or other plants thanks to this technique.

Offering an additional function as a launch platform was another intriguing design concept for the packaging. The case can be used as a launch pad for the blimp by fully opening it. This technology would boost safety during the launch process and make it simple for customers to launch the blimp from a secure place.

In conclusion, the blimp's packaging for telesurveillance of big farms in Australia was created to be both user-friendly and environmentally responsible.

7.4.3.2 Material solutions

Table 74 describes the top 5 cardboard for packaging.

Table 74: Top 5 cardboard for packaging [\[Phil Forbes, 2022\]](#) [\[Carton Market, 2023\]](#)

Type of cardboard	Price (€/m ²)	Weight (g/m ²)	Rigidity (N.m/kg)	Recyclability	Source
Solid fibreboard	1.10	440	2.2	Yes	[Pierre Grante, 2022]
Corrugated cardboard	0.80	230	1.5	Yes	[Pierre Grante, 2022]
Kraft paper	0.50	120	1.0	Yes	[Pierre Grante, 2022]
News paper	0.20	50	0.5	Yes	[Pierre Grante, 2022]
Foam cardboard	1.50	200	1.2	No	[Pierre Grante, 2022]

According to our company's study, solid fibreboard appears to be the most rigid and recyclable material for our project. But it also costs more than corrugated cardboard. The relative importance of each of these factors will determine the selection. The fact that both kinds of cardboard can be recycled should not be overlooked. Solid fibreboard would be the greatest option if we want a more rigid packing, but corrugated cardboard would be a decent choice if we are prepared to give up some rigidity in order to save money.

There are also other materials that could potentially meet the same criteria as cardboard for our

packaging needs. One option is polypropylene [Corplex, 2020], a thermoplastic material that is strong, lightweight, and recyclable. Another option is corrugated plastic, which is also lightweight and durable, with the added benefit of being waterproof. However, both of these materials tend to be more expensive than cardboard.

According to the website of a Portuguese packaging supplier, the cost per sheet of cardboard ranges from 0.15 € to 1.50 €, depending on the size and thickness of the sheet. On the other hand, the cost per sheet of polypropylene ranges from 0.45 € to 9.50 €, while the cost per sheet of corrugated plastic ranges from 1.20 € to 5.50 €.

In terms of environmental impact, both polypropylene and corrugated plastic can be recycled, but cardboard is generally considered to be the more sustainable option due to its biodegradability and widespread availability of recycling facilities.

Overall, it appears that cardboard is still the most cost-effective and eco-friendly option for our packaging needs, especially considering its versatility and potential for reuse. However, it may be worth exploring other materials in the future as technology and innovation continue to advance in the packaging industry.

7.4.3.3 3D Model

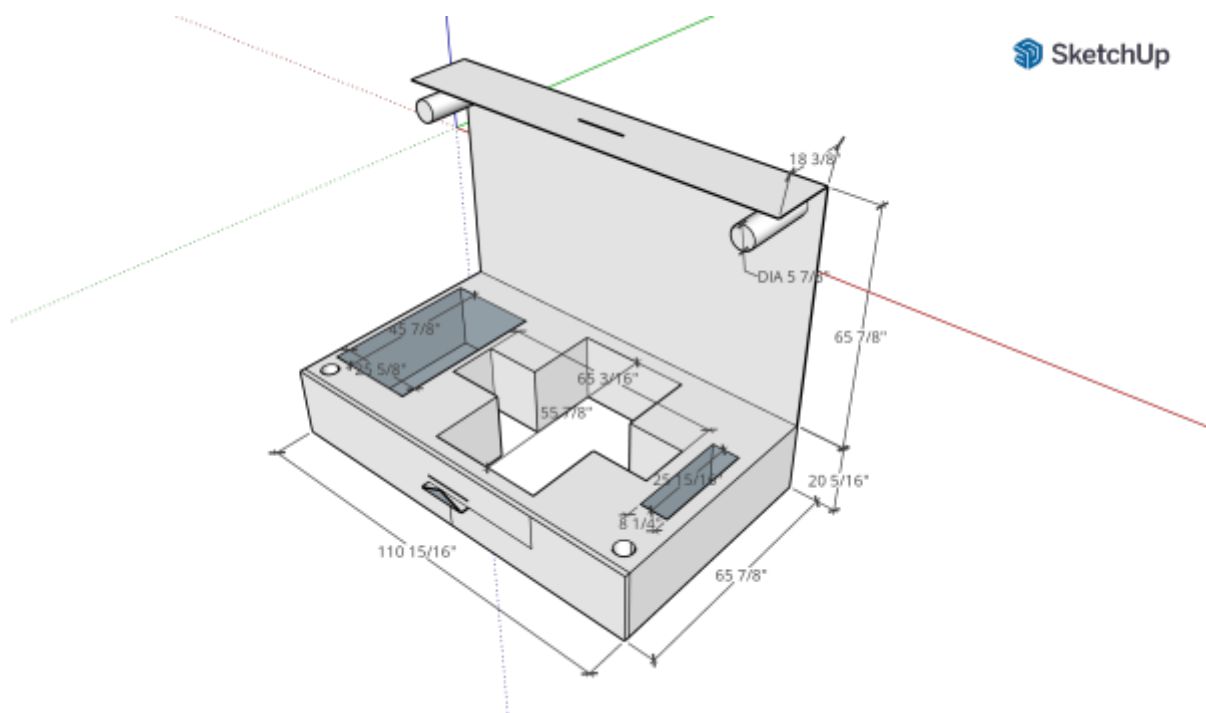

Figure 65: Packaging Model

7.5 Prototype

7.5.1 Structure

In relation to the designed solution several changes were made. Most of them regarding the design of the parts due to the different manufacturing technique. The designed solution will be manufactured

through injection molding while the prototype is 3D-printed. Because of that the printability of the parts is a limiting factor in terms of shape. Figure 66 conveys the overall design.

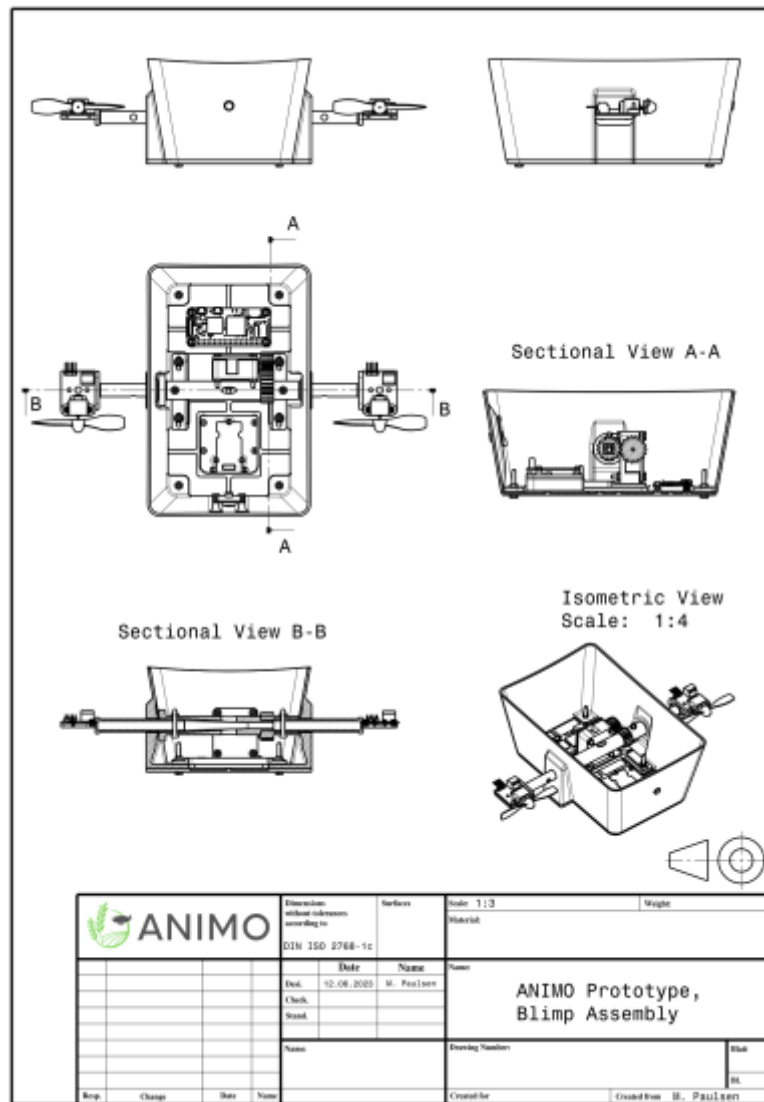
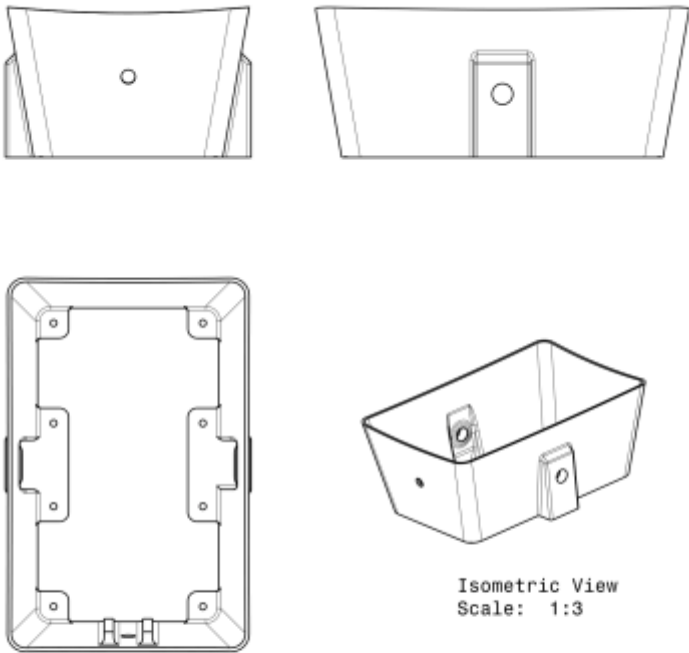



Figure 66: Structural draft of the blimp prototype

One major change is that the gondola, shown in figure 67, and the lid, also shown in figure 67, are shortened and the angle of the walls differs from the original, so the distance between the most upper edges of the gondola doesn't exceed 200 mm, which is the maximum length that can be printed at ISEP. In addition, in certain areas of the lid material was removed in such a way, that the lid of the prototype is thinner with some reinforcing struts that have the same thickness as the original part. So the overall mass is lower, but the stiffness and strength are approximately the same. This design is also beneficial for the process of 3D-printing the part, because the probability of warping is significantly lower.



Isometric View
Scale: 1:3



 ANIMO	Dimensione indicare solo se secondo le norme DIN ISO 2768-1c	Surface	Scale: 1:2	Height
			Material:	
			Name: ANIMO Prototype, Gondola	
			Drawing Number:	Mat:
				Bl:
Rev:	Change	Date	Name	Created for
				Created from: M. Poggiani

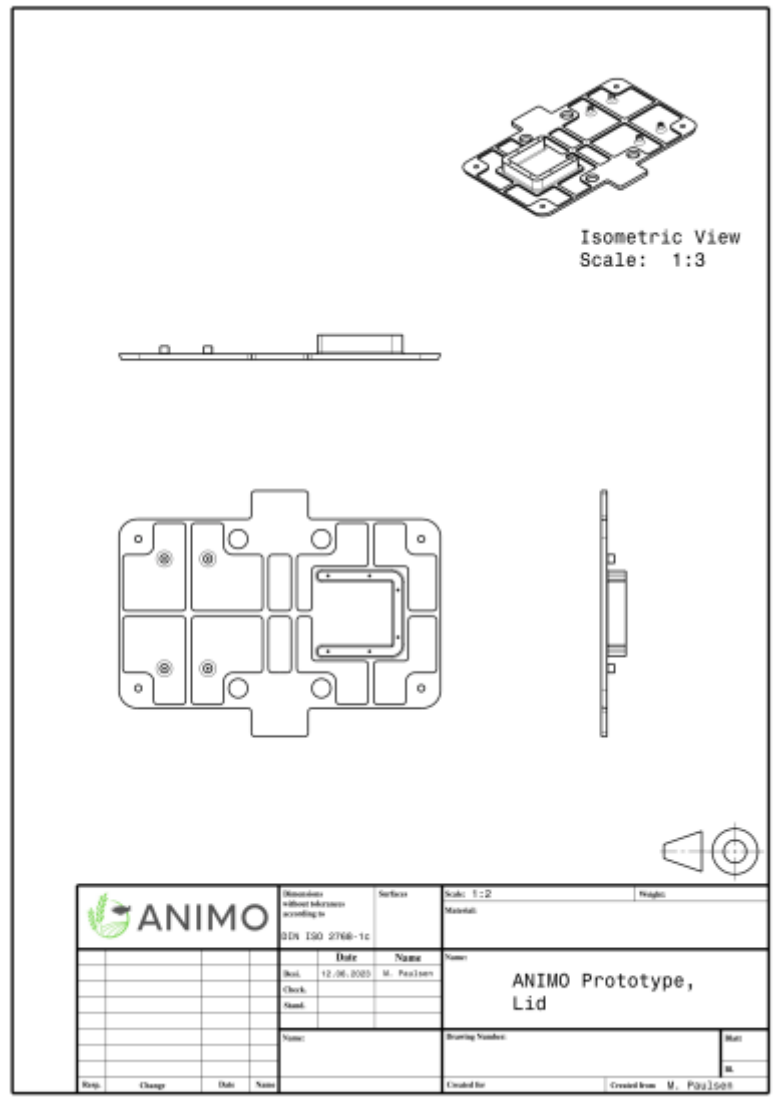

Figure 67: Structural drafts of the gondola and the detachable bottom, named lid

The same design principle was applied to the servo motor mounting plate (figure 68.

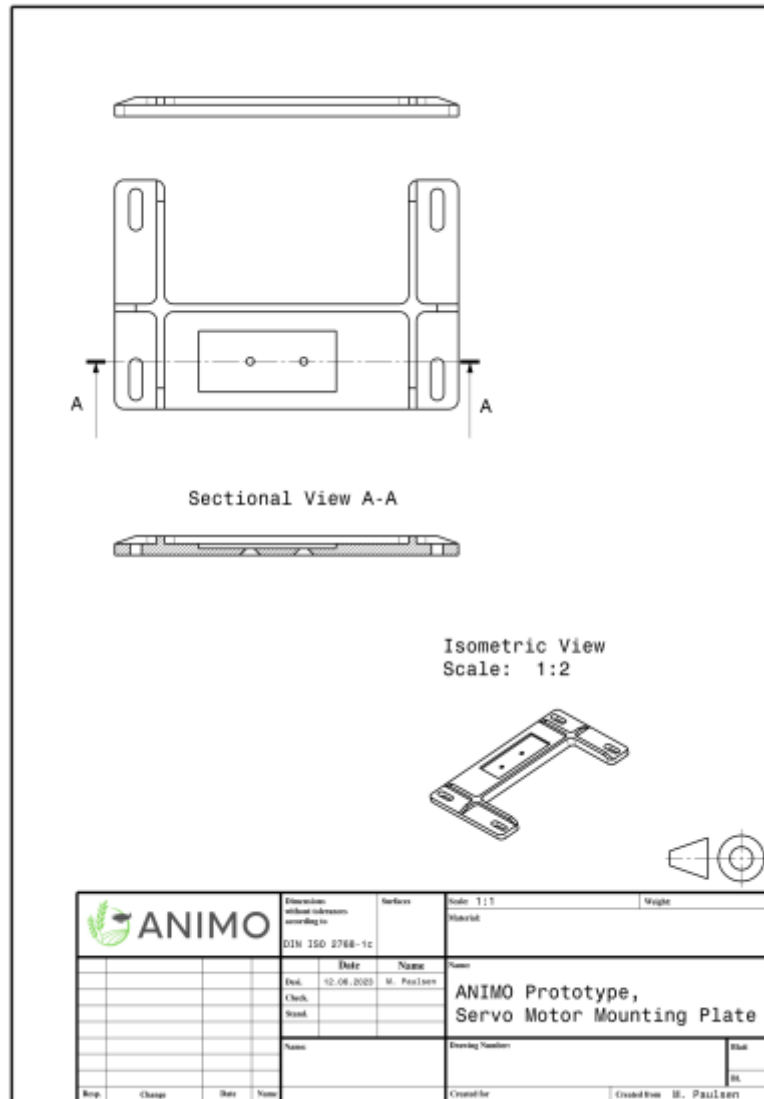

Figure 68: Structural draft of the adjustable mounting for the servo motor

Further changes due to printability were made to the coupling, the arms and the servo motor mounting. All of them were split into two parts each, in order to minimize the support structure needed for the print and to align the layers of the print, in relation to the installation direction of the parts, in a favorable way. The two-part coupling is shown on the right in figure 69. Like in the original design the arms are slid into the ends of the hollow coupling and mounted with screws and nuts as shown on the left of figure 69.

Sectional View A-A

Isometric View

	Dimension without tolerances according to DIN ISO 2768-1c		Surfaces	Scale 1:2	Weight
	Date: 12.08.2023 Check: Stand:		Name: M. Paulsen	Name: ANIMO Prototype, Arm Assembly	
Name:			Drawing Number:		Date:
Drawn by:			Created by:		Created from: H. Paulsen

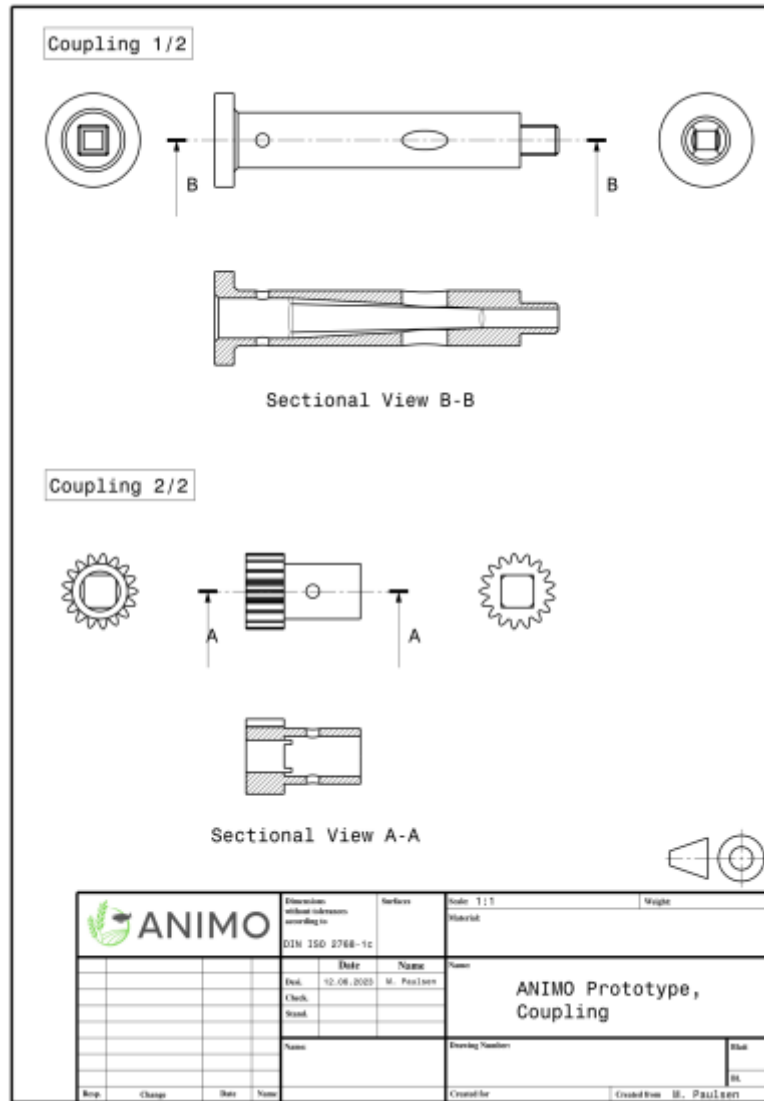

Figure 69: Structural drafts of the assembly of the arm-coupling subassembly and the coupling itself

7.5.2 Hardware

Regarding the original product, a few hardware changes have been made. The microcontroller has been replaced with the less powerful Zero W. The original product's two batteries have been replaced with a single, but heavier one. For the sake of simplicity, ready-made propeller modules were used as the propulsion units for the prototype. Another GNSS sensor is also used. This way most of the functionalities of the blimp can be realized in a cost reducing manner. The wiring of the components is displayed in figure 70.

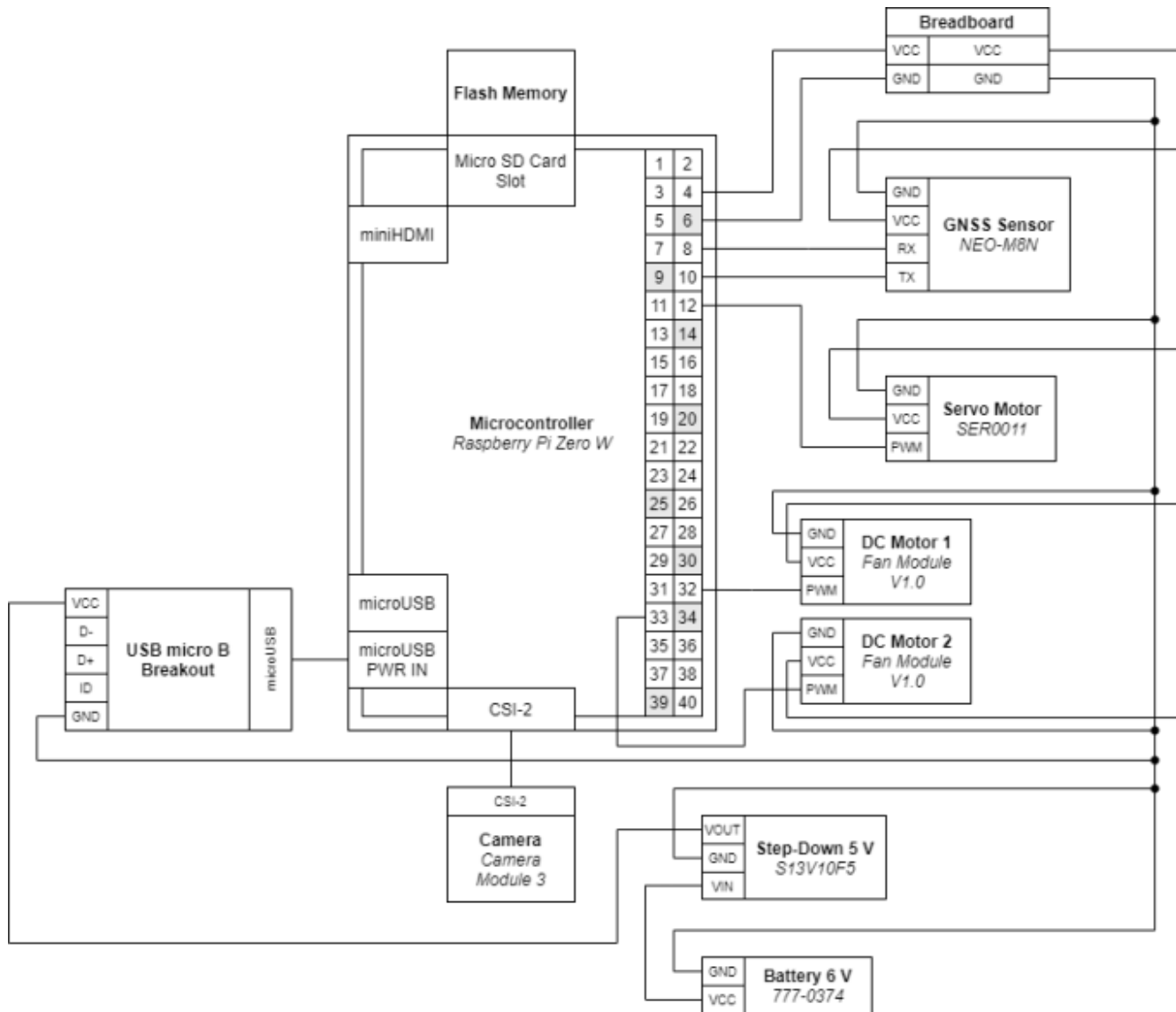

Figure 70: System schematics of the ANIMO prototype

The parts in the following table were used for the prototype.

Electronic Components for the Prototype

Nb.	Part Number	Manufacturer	Part	Price (€)	Transportation (€)	Mass [g]	Dimensions [mm]	Interface	Provider
1.	MIKROE 4086	MIKROELEKTRONIKA	IMU	6.84	3.50	17.0	42.9 x 25.4	I2C, SPI	[RS, 2023]
2.	SC0872 Raspberry Pi Camera Module 3	Raspberry Pi	Camera	22.99	14.00	15.9	25 x 24 x 11.5	CSI-2, I2C	[Farnell, 2023]
3.	RS PRO 777-0374	RS Pro	Battery	18.63	3.50	105			[RS, 2023]
4.	SER0011	DFRobot	Servo-Motor	7.81	22.00	14.7	23 x 12 x 28.8	PWM	[DigiKey, 2023]
5.	109020022	Seed-Studio	GNSS Sensor	12.31	20.00	10		UART	[Mouser, 2023]
				68.58	63.00				

Material for the Envelope for the Prototype

Nb.	Part Number	Part	Price (€)	Mass [g]	Material	Provider
1.	Bola Insuflável Gigante Bagge - INNOVAGOODS	envelope	14.40	no information available	TPR	https://www.castroelectronica.pt/fr/product/bola-insuflavel-gigante-bagge--innovagoods

7.5.3 Software

For the prototype app, we used the same technologies as the designed solution. However, we made a slight alteration by employing web sockets instead of a cloud-based service like AWS. This decision was primarily driven by budget constraints and the simplicity it offered during the prototype phase.

The app's functionality includes:

- **Authentication:** The app features an authentication page operated by auth0, ensuring secure user access.
- **Farm Creation and Selection:** Once authenticated, users can either create a new farm or choose an existing one.
- **Dashboard:** After logging in, users are redirected to a dashboard where they can access various features.
- **Blimp List:** The dashboard displays a list of available blimps for the selected farm.
- **Adding Blimps:** Users have the ability to add new blimps to their farm directly from the dashboard.
- **Map View:** The app provides a map view that shows the locations of all the blimps within the selected farm.
- **Blimp Profiles:** Each blimp on the map has a corresponding profile, providing additional information.
- **Detailed Blimp Information:** By clicking on a specific blimp, users can access precise location details and additional controls for that blimp.

This comprehensive functionality allows users to seamlessly interact with the app, managing their blimps and monitoring their locations in real-time.

The flow of the app is shown in table 71 below, which illustrates the sequence of actions and interactions within the application. This flow showcases the logical progression and functionality of the app.

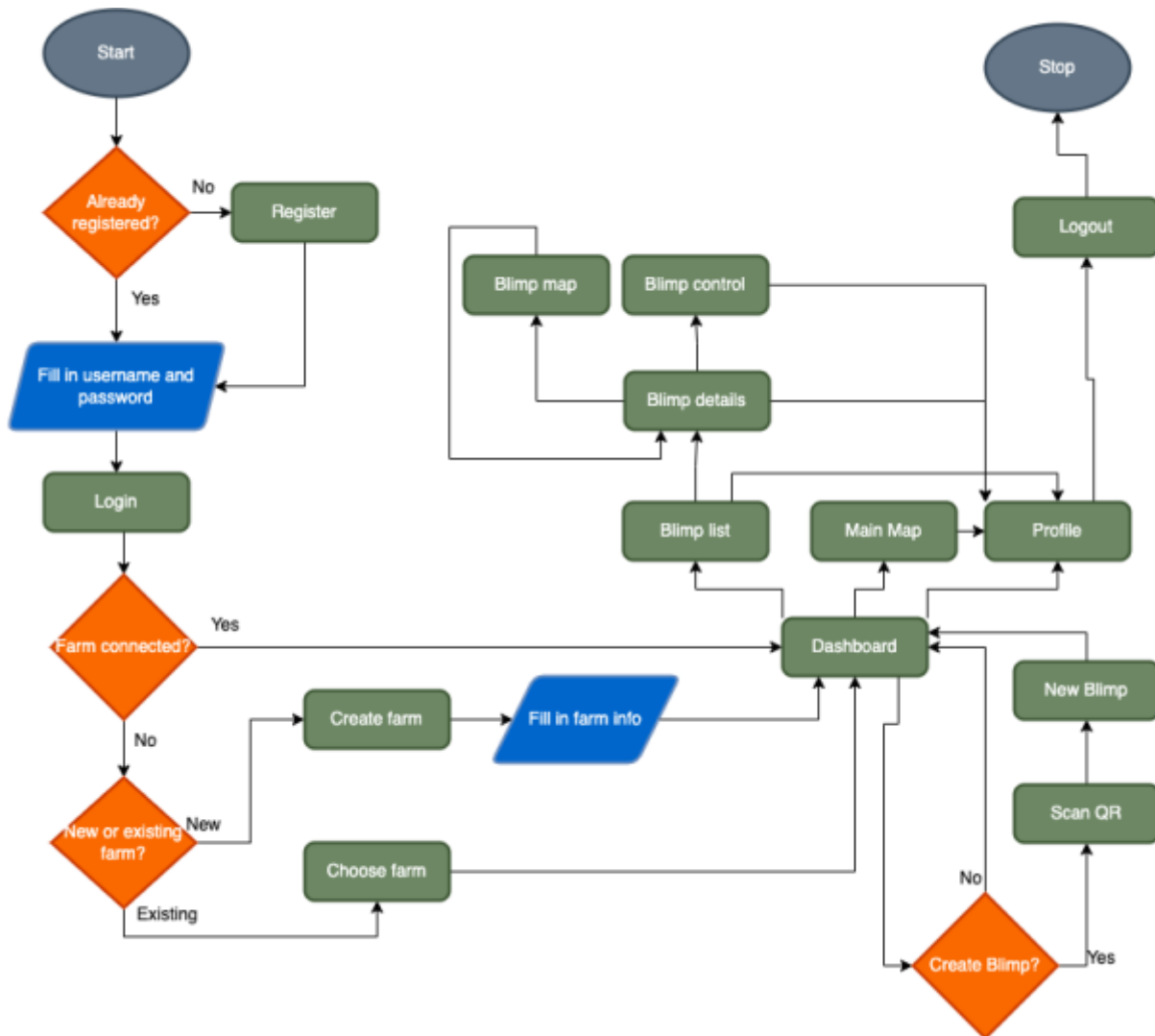

Figure 71: Flowchart prototype app

The code for creating the prototype app can be found in the following link: [Github repository](#)

The visual representation of the app can be found in the below figures 72 73 74. below. This image provides a visual overview of the app's user interface and design.

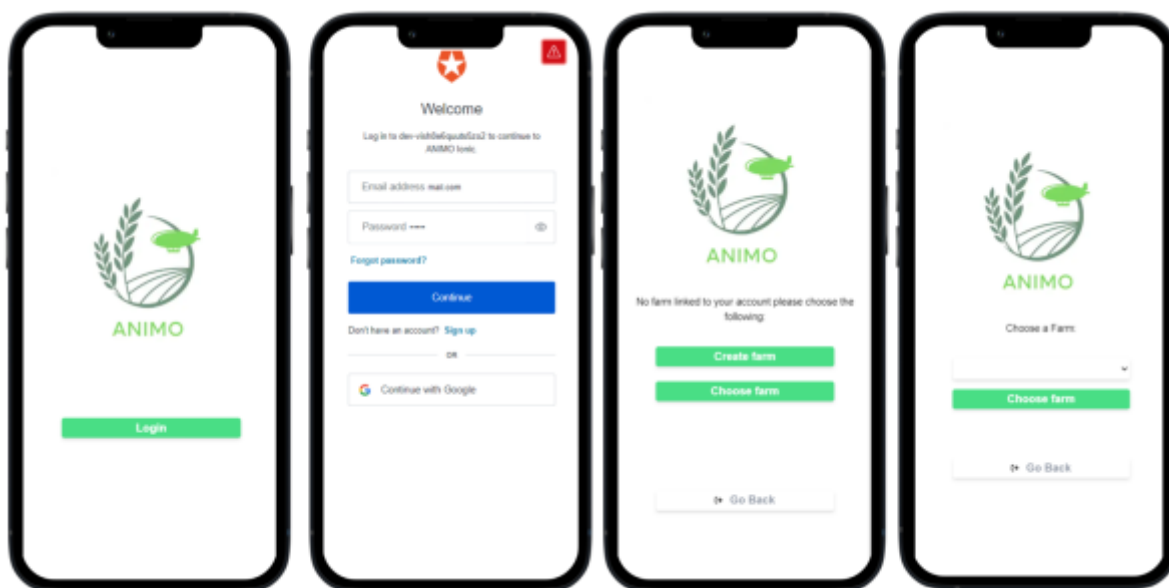

Figure 72: Prototype visual 1

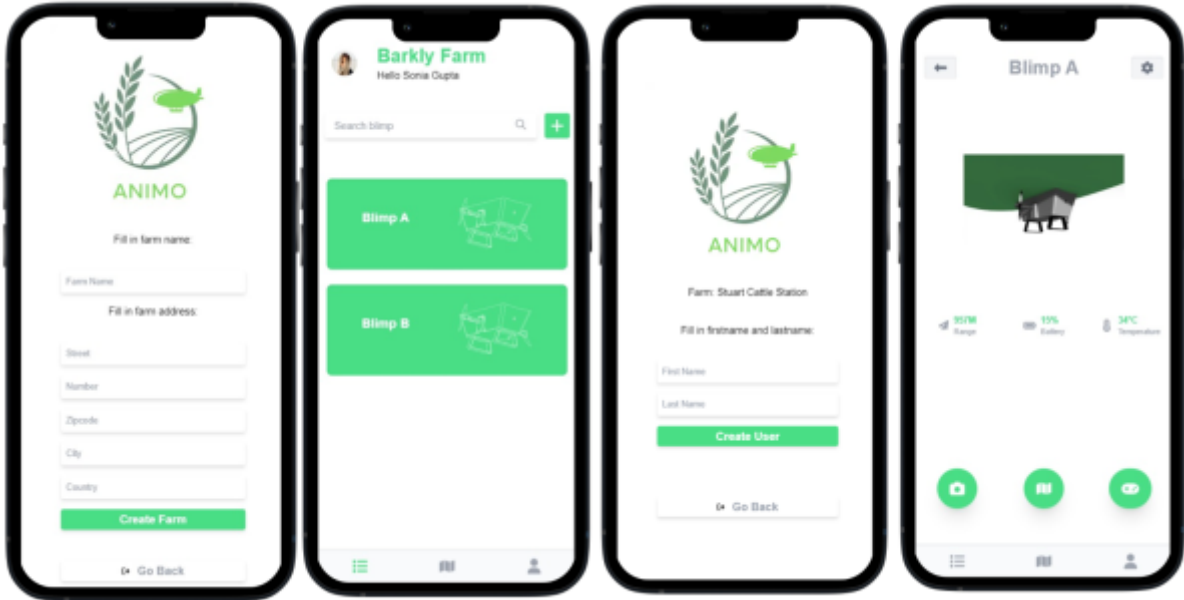

Figure 73: Prototype visual 2



Figure 74: Prototype visual 3

7.5.4 Tests & Results

Software tests

The results of our API functionality and performance tests, specifically focusing on latency, can be found in Table 75 . Using Postman, we measured the response times and throughput of the API in various scenarios. The captured data allowed us to analyse and optimise the API speed and reliability, ensuring that the observed latency remained within acceptable limits. Table 75 provides a comprehensive overview of the latency results, highlighting the efficiency of the API in delivering timely responses.

Table 75: API: Functional and performance results

Functionality	Method	Result	Size (B)	Latency	
				μ	σ
Address					
/api/addresses	GET	OK	465	10,20	1,30
/api/addresses	POST	OK	347	12,00	3,54
/api/addresses	PUT	OK	353	9,00	1,41
/api/addresses/{id}	DELETE	OK	257	12,20	3,70
/api/addresses/{id}	GET	OK	366	9,20	5,54
Blimp					
/api/blimps	GET	OK	716	8,80	3,63
/api/blimps	POST	OK	405	10,60	4,04
/api/blimps	PUT	OK	482	9,60	1,95
/api/blimps/{id}	DELETE	OK	257	11,00	5,39
/api/blimps/{id}	GET	OK	484	9,60	4,34
Farm					
/api/farms	GET	OK	554	10,80	7,46
/api/farms	POST	OK	405	11,40	5,68
/api/farms	PUT	OK	398	8,80	2,95
/api/farms/{id}	DELETE	OK	257	12,80	8,04
/api/farms/{id}	GET	OK	399	7,40	2,70
User					
/api/users	GET	OK	1003	8,40	2,51
/api/users	POST	OK	506	12,20	5,02
/api/users	PUT	OK	499	11,40	5,13
/api/users/{id}	DELETE	OK	257	8,20	1,79
/api/users/{id}	GET	OK	502	8,40	5,94

To evaluate the performance of our API under different load conditions, we conducted comprehensive load testing. By identifying the API endpoint with the highest latency, we focused our analysis on its behaviour under increasing load levels, specifically with batches of 10, 100, and 1000 requests. These load testing results, including the latency measurements, can be found in Table 76, providing valuable insights into the scalability and responsiveness of the API and guiding our optimisation efforts to ensure a reliable experience for our users.

Table 76: API: load results

Request	Functionality	Method	Results	Size (B)	Latency	
					μ	σ
10	/api/farms/id	DELETE	10	257	6,00	2,31
100	/api/farms/id	DELETE	100	257	4,73	1,02
1000	/api/farms/id	DELETE	1000	257	3,66	0,64

7.6 Conclusion

In conclusion, Chapter 7 takes us through the pivotal stages of ideation, concept development, design, and prototyping, which collectively form the foundation of our project's development.

During the ideation phase, our team engaged in extensive research and analysis to identify gaps in the market and generate innovative ideas. Through this process, we harnessed creativity and critical thinking to address specific problems and meet user needs effectively.

The concept development phase enabled us to refine and shape our ideas, considering feasibility factors and aligning them with our overarching goals. Collaborative efforts and a diverse range of expertise were instrumental in ensuring the practicality and viability of the proposed concepts.

The subsequent design and prototyping stages involved translating our conceptualized ideas into tangible representations. Through sketches, diagrams, and computer-aided design tools, we meticulously crafted the visual and functional aspects of our project. Iterative prototyping allowed us to evaluate and refine our designs, ultimately resulting in a functional prototype that was thoroughly tested for performance, functionality, and user experience.

Overall, Chapter 7 underscores the importance of a systematic and iterative approach in transforming initial ideas into tangible outcomes. It highlights the significance of creativity, research, collaboration, attention to detail, and feasibility considerations in the development process. The insights gained from this chapter provide a strong foundation for the subsequent chapters, where we will delve deeper into the results, analysis, and advancements of our project.

The next chapter, "Conclusions," will provide a comprehensive discussion of the project's outcomes, implications, and future development prospects.

8. Conclusions

8.1 Discussion

At the end of our Erasmus project in the European project semester, we were able to achieve several initial objectives related to the production of a blimp designed for livestock control and surveillance in large farms, also known as "stations". To fully accomplish our goals, we followed a systematic approach by conducting:

- A detailed state-of-the-art analysis.
- Marketing analysis.
- Ethics analysis.
- Sustainability analysis.
- Management analysis.

First and foremost, we succeeded in designing and manufacturing a functional prototype of a blimp equipped with sensors and control systems. The purpose of this blimp is to fly over the vast expanses of the stations and collect data on livestock, including their location and, through the camera, their behavior, from which numerous insights can be derived. Furthermore, we have effectively developed

a user-friendly and intelligent mobile application that empowers farmers to control the blimp with ease and efficiency.

However, there are still some aspects to be tested in order to address the identified gaps regarding our initial objectives. Firstly, the battery life of the blimp could be extended to optimize flight time and data collection. Currently, the energy capacity may limit the range and operational efficiency of the blimp. We also need to explore improvements in resistance to adverse weather conditions, particularly strong winds, to ensure continuous livestock surveillance. Additionally, one of the objectives we could not achieve was the exclusive use of 100% renewable materials, unlike the Acrylonitrile Styrene Acrylate and Vectran used in our blimp.

In conclusion, this group work experience has been extremely enriching, allowing us to collaborate effectively and tackle challenges together. We diligently adhered to weekly deadlines, actively participating in work meetings, which enabled us to maintain a productive pace. This experience has provided us with a better understanding of project management, improved communication skills, and an appreciation for the value of teamwork in accomplishing a complex project.

8.2 Future Development

To further enhance the project, we recommend taking the following actions:

- **Full-scale development:** It would be beneficial to construct the blimp at its actual size to conduct tests in real-world conditions on large farms. This would allow us to gather valuable data on the blimp's effectiveness in real agricultural environments and identify further potential improvements.
- **Integration of artificial intelligence:** An essential feature for the blimp would be the addition of artificial intelligence capabilities for automatic movement based on livestock tracking. This would enable proactive animal monitoring and real-time adjustments to flight routes. However, to incorporate this functionality, the blimp's autonomy would also need improvement to ensure extended operations.
- **Enhancement of camera capabilities:** The camera plays a crucial role in collecting data on livestock. To further improve the blimp's functionality, it would be valuable to add additional parameters to the camera, such as night vision or infrared capabilities. This would enable more comprehensive livestock monitoring and provide valuable insights into their behavior, health, and well-being.

By implementing these recommendations, we can continue to enhance the blimp and optimize its use in livestock surveillance. These future developments would strengthen the performance, accuracy, and efficiency of the blimp, contributing to advanced and sustainable animal management in large farms.

Bibliography

[European Project Semester, 2023] European Project Semester, 2023. *European Project Semester*. [Accessed in March 2023].

[Yue Wang, Gang Zheng, Denis Efimov, Wilfrid Perruquetti, 2020] Yue Wang, Gang Zheng,

- Denis Efimov, Wilfrid Perruquetti, 2020. [Disturbance compensation based controller for an indoor blimp robot](#). *Robotics and Autonomous Systems*, 124, pp.103402, ISSN 0921-8890.
- [Geoffrey Hollinger, Zachary Pezzementi, Alexander Flurie, Bruce Maxwell, 2005]**, **[Geoffrey Hollinger, Zachary Pezzementi, Alexander Flurie, Bruce Maxwell, 2005]** Geoffrey Hollinger, Zachary Pezzementi, Alexander Flurie, Bruce Maxwell, 01 2005. [Design and Construction of an Indoor Robotic Blimp for Urban Search and Rescue Tasks](#). Swarthmore College Senior Design Thesis, pp.19.
- [Melissa Eddy, 2011]** Melissa Eddy, 2011. [Goodyear blimp -advertising safety - crashes](#). *cs monitor*, [Accessed in March 2023].
- [Durga Vasudevan, Hariharan Mohan, Saarang Gaggar, Ramesh Burela Gupta, 2019]** Durga Vasudevan, Hariharan Mohan, Saarang Gaggar, Ramesh Burela Gupta, 2019. [Design and sizing of an airship supported by CAE](#).
- [Aero Drum Ltd, 2018]** Aero Drum Ltd, 2018. [5 m Outdoor Blimp](#). [Accessed in March 2023].
- [Ying Hong Peh, Shane Kyi Hla Win, Shaohui Foong, 2022]** Ying Hong Peh, Shane Kyi Hla Win, Shaohui Foong, 2022. [Spherical Indoor Coandă Effect Drone \(SpICED\): A Spherical Blimp sUAS for Safe Indoor Use](#). *Drones*, 9, pp.30.
- [Dave Rowntree, 2021]** Dave Rowntree, 2021. [Indoor Blimp Sails Through The Air Using Ultrasonic Transducers](#). [Accessed in March 2023].
- [Dan Goebel, Richard Wirz, Israel Katz, 2007]** Dan Goebel, Richard Wirz, Israel Katz, 09 2007. Analytical Ion Thruster Discharge Performance Model. *Journal of Propulsion and Power*, 23, pp.1055-1067.
- [Karl Hastrich, 2011]** Karl Hastrich, 2011. [Flying Penguins and Mechanical Jellyfish to Change the World](#). [Accessed in March 2023].
- [Ltd. Murata Manufacturing Co., 2023]** Ltd. Murata Manufacturing Co., 2023. [Basic knowledge of microblower \(Air pump\)](#). [Accessed in March 2023].
- [Mike Chino, 2010]** Mike Chino, 2010. [Solar-powered blimp set to fly across Channel](#). *The Guardians*, [Accessed in March 2023].
- [Paul Ridden, 2010]** Paul Ridden, 2010. [Zeppy 3: wind-powered airship to attempt Mediterranean crossing](#). [Accessed in March 2023].
- [Stephen J. Mraz, 2022]** Stephen J. Mraz, 2022. [Building the Hydrogen Highway](#). [Accessed in March 2023].
- [Elizabeth Stoeckmann, 2017]** Elizabeth Stoeckmann, 2017. [Aloft and Alert](#). *DLA Energy Public Affairs*, [Accessed in March 2023].
- [Mark Piesing, 2019]** Mark Piesing, 2019. [Airships lost out to conventional aircraft after a series of disastrous crashes. But now safer technology could be the key to their return..](#) *BBC*, [Accessed in March 2023].
- [Jake Epstein, 2021]** Jake Epstein, 2021. [Not a bird, not a plane: Startup hopes to hit skies with 'eco-friendly' blimps](#). *The Times of Israel*, [Accessed in March 2023].
- [Murdo Morrison, 2020]** Murdo Morrison, 2020. [Israeli developer has freight expectations for hybrid airship](#). [Accessed in March 2023].
- [Miquel Ros, 2023]** Miquel Ros, 2023. [Ariane rockets to be carried by airships, new deal with Flying Whales reveals](#). [Accessed in March 2023].
- [Alicia Chang, 2006]** Alicia Chang, 2006. [Robo-blimps could bring you wireless](#). *NBC News*, [Accessed in March 2023].
- [Roger, 2020]** Roger, 2020. [How to Use RFID Technology for Cattle Tracking](#). [Accessed in March 2023].
- [Kaitlyn Wells, 2021]** Kaitlyn Wells, 2021. [The Best GPS Dog Collars and Pet Trackers](#). [Accessed in March 2023].
- [Rajni Setia, 2020]** Rajni Setia, 2020. [Role of IoT in Promoting Livestock Health through Remote Monitoring and Data-Driven Decision-Making](#). [Accessed in March 2023].
- [Xiaohui Li, Hailong Huang, Andrey V. Savkin, Jian Zhang, 2022]** Xiaohui Li, Hailong Huang,

- Andrey V. Savkin, Jian Zhang, 2022. [Robotic Herding of Farm Animals Using a Network of Barking Aerial Drones](#). *Drones*, 6, ISSN 2504-446X.
- [Matthias Zuerl, Philip Stoll, Ingrid Brehm, René Raab, Dario Zanca, Samira Kabri, Johanna Happold, Heiko Nille, Katharina Prectel, Sophie Wuensch, Marie Krause, Stefan Seegerer, Lorenzo von Fersen, Bjoern Eskofier, 2022]** Matthias Zuerl, Philip Stoll, Ingrid Brehm, René Raab, Dario Zanca, Samira Kabri, Johanna Happold, Heiko Nille, Katharina Prectel, Sophie Wuensch, Marie Krause, Stefan Seegerer, Lorenzo von Fersen, Bjoern Eskofier, 2022. [Automated Video-Based Analysis Framework for Behavior Monitoring of Individual Animals in Zoos Using Deep Learning -- A Study on Polar Bears](#). *Animals*, 12, ISSN 2076-2615.
- [Lara Silva, 2022]** Lara Silva, Sep 2022. [Guide to Social Security in Portugal](#). *Portugal.com*.
- [Corporate Finance Institute, 2020]** Corporate Finance Institute, 2020. [Quality Management](#). [Accessed in March 2023].
- [Harshal Shah, 2021]** Harshal Shah, 2021. [Understanding Triple Constraint: The Project Management Triangle](#). [Accessed in March 2023]: project-management.com.
- [Rose Keefe, 2018]** Rose Keefe, Aug 2018. [The Triple Constraints of Project Management and Why They Matter](#). *Toggl Blog*.
- [Jason Fernando, 2023]** Jason Fernando, 2023. [What Are Stakeholders: Definition, Types, and Examples](#). [Accessed in March 2023]: [Investopedia](https://investopedia.com).
- [Manager Project, 2023]** Manager Project, 2023. [Stakeholder Management](#). [Accessed in March 2023].
- [Bryan Kitch, 2023]** Bryan Kitch, 2023. [How to Create a Stakeholder Map \[Templates & Examples\]](#). [Accessed in March 2023].
- [Nuclino, 2023]** Nuclino, 2023. [What is a Sprint Review? Definition, Purpose, and Template](#). [Accessed in March 2023].
- [Wrike, 2023]** Wrike, 2023. [What Is the Goal of Sprint Retrospective Meeting?](#). [Accessed in March 2023].
- [Meat, Livestock Australia, 2023]** Meat, Livestock Australia, 2023. [Trends & analysis](#). [Accessed in March 2023].
- [Australian Bureau of Statistics, 2023]** Australian Bureau of Statistics, 2023. [Welcome to the Australian Bureau of Statistics](#). [Accessed in March 2023].
- [International Competence Center on Large Scale Agriculture, 2018]** International Competence Center on Large Scale Agriculture, 2018. [Top 10 Australia's Biggest Cattle Stations](#). [Accessed in March 2023].
- [State Library of New South Wales, 2023]** State Library of New South Wales, 2023. [Australian agricultural and rural life](#). [Accessed in March 2023].
- [Entegra Signature Structures, 2020]** Entegra Signature Structures, 2020. [Anna Creek - The biggest Cattle Station in Australia](#). [Accessed in March 2023].
- [Australian Bureau of Statistics, 2020]** Australian Bureau of Statistics, 2020. [Welcome to the Australian Bureau of Statistics](#). [Accessed in March 2023].
- [Santander Universidades, 2022]** Santander Universidades, 2022. [What is sustainability? Definition, types and examples](#). [Accessed in March 2023].
- [MasterClass, 2022]** MasterClass, 2022. [Economic Sustainability: Definition, Importance, and Examples](#). [Accessed in March 2023].
- [Suzanne Vallance, Harvey C. Perkins, Jennifer E. Dixon, 2011]** Suzanne Vallance, Harvey C. Perkins, Jennifer E. Dixon, 2011. [What is social sustainability? A clarification of concepts](#). *Geoforum*, 42, pp.342-348, ISSN 0016-7185.
- [Jeroen B. Guinée, Reinout Heijungs, Gjalt Huppes, Alessandra Zamagni, Paolo Masoni, Roberto Buonamici, Tomas Ekvall, Tomas Rydberg, 2011]** Jeroen B. Guinée, Reinout Heijungs, Gjalt Huppes, Alessandra Zamagni, Paolo Masoni, Roberto Buonamici, Tomas Ekvall, Tomas Rydberg, 2011. [Life Cycle Assessment: Past, Present, and Future](#). *Environmental Science & Technology*, 45, pp.90-96.

- [Prabhakar Krishnamurthy, 2011]** Prabhakar Krishnamurthy, 2011. *An Introduction to Ethics*. SSRN Electronic Journal, Elsevier.
- [William M. Marcy, Jane B. Rathbun, 2017]** William M. Marcy, Jane B. Rathbun, 2017. *Engineering Ethics and Its Impact on Society*. [Accessed in March 2023]: The Ethical Engineer.
- [Pankaj M. Madhani, 2020]** Pankaj M. Madhani, 2020. *Ethics in Sales and Marketing: Key Advantages*. *Marketing Mastermind*, 17, pp.53-58.
- [Fabio Zagonari, 2020]** Fabio Zagonari, 2020. Environmental sustainability is not worth pursuing unless it is achieved for ethical reasons. *Palgrave Communications*, 6, Palgrave, pp.1-8.
- [Jacob M. Appel, 2019]** Jacob M. Appel, 2019. *When Liability and Ethics Diverge*. *Focus*, 17, pp.382-386.
- [Casey Stockbridge, Alessandro Ceruti, Pier Marzocca, 2012]** Casey Stockbridge, Alessandro Ceruti, Pier Marzocca, 06 2012. Airship Research and Development in the Areas of Design, Structures, Dynamics and Energy Systems. *International Journal of Aeronautical and Space Sciences*, 13, pp.170-187.
- [E. Callut P. Hendrick M. Duponcheel N. Caeymax J. Buret S. Gohy L. Fitschy O. Banse M. Bruyneel, 2019], [E. Callut P. Hendrick M. Duponcheel N. Caeymax J. Buret S. Gohy L. Fitschy O. Banse M. Bruyneel, 2019]** E. Callut P. Hendrick M. Duponcheel N. Caeymax J. Buret S. Gohy L. Fitschy O. Banse M. Bruyneel, 09 2019. Analysis and retardation of helium permeation for high altitude airship envelope material. *AIP Conference Proceedings*, 2148, ISSN 0094-243X.
- [Mouser, 2023], [Mouser, 2023], [Mouser, 2023], [Mouser, 2023], [Mouser, 2023], [Mouser, 2023], [Mouser, 2023], [Mouser, 2023], [Mouser, 2023], [Mouser, 2023], [Mouser, 2023], [Mouser, 2023], [Mouser, 2023], [Mouser, 2023], [Mouser, 2023], [Mouser, 2023], [Mouser, 2023], [Mouser, 2023]** [Accessed in March 2023]
- [RS, 2023], [RS, 2023], [RS, 2023], [RS, 2023], [RS, 2023], [RS, 2023], [RS, 2023], [RS, 2023], [RS, 2023], [RS, 2023], [RS, 2023], [RS, 2023], [RS, 2023], [RS, 2023], [RS, 2023], [RS, 2023], [RS, 2023], [RS, 2023]**
<https://pt.rs-online.com/web/>
- [DigiKey, 2023], [DigiKey, 2023], [DigiKey, 2023], [DigiKey, 2023], [DigiKey, 2023], [DigiKey, 2023], [DigiKey, 2023], [DigiKey, 2023], [DigiKey, 2023], [DigiKey, 2023], [DigiKey, 2023], [DigiKey, 2023], [DigiKey, 2023], [DigiKey, 2023], [DigiKey, 2023]** <https://www.digikey.pt/en>
- [Electrofun, 2023], [Electrofun, 2023], [Electrofun, 2023], [Electrofun, 2023], [Electrofun, 2023], [Electrofun, 2023], [Electrofun, 2023], [Electrofun, 2023]** <https://www.electrofun.pt/>
- [Farnell, 2023], [Farnell, 2023], [Farnell, 2023], [Farnell, 2023], [Farnell, 2023], [Farnell, 2023], [Farnell, 2023], [Farnell, 2023], [Farnell, 2023], [Farnell, 2023], [Farnell, 2023], [Farnell, 2023], [Farnell, 2023], [Farnell, 2023], [Farnell, 2023], [Farnell, 2023], [Farnell, 2023], [Farnell, 2023]** [Accessed in March 2023]
- [PT Robotics, 2023], [PT Robotics, 2023], [PT Robotics, 2023], [PT Robotics, 2023]** <https://www.ptrobotics.com/>
- [Mauser, 2023]** <https://mauser.pt/catalog/>
- [botnroll, 2023], [botnroll, 2023], [botnroll, 2023], [botnroll, 2023], [botnroll, 2023], [botnroll, 2023], [botnroll, 2023], [botnroll, 2023]** <https://www.botnroll.com/pt/>
- [Phil Forbes, 2022]** Phil Forbes, 2022. *Types Of Cardboard Used In The Packaging Industry*. [Accessed in March 2023]: Packhelp.
- [Carton Market, 2023]** Carton Market, 2023. *Cornières, coins, plaques en carton*. [Accessed in March 2023].
- [Pierre Grante, 2022], [Pierre Grante, 2022], [Pierre Grante, 2022], [Pierre Grante, 2022], [Pierre Grante, 2022]** Pierre Grante, 2022. *Ce que sont les différents types de carton*. [Accessed in March 2023]: Packhelp.

[Corplex, 2020] Corplex, 2020. *Akilux® Plaques de Polypropylène Alvéolaire*. [Accessed in March 2023]: Corplex.

From:

<https://www.eps2023-wiki5.dee.isep.ipp.pt/> - **EPS@ISEP**

Permanent link:

<https://www.eps2023-wiki5.dee.isep.ipp.pt/doku.php?id=report>

Last update: **2023/06/21 18:13**

